

Raising Healthy Pigs

FOURTH EDITION - REVISED

by

Dr. D.E. Goodman

Turbeville, South Carolina



**Christian
Veterinary
Mission**

Christian Veterinary Mission
Current Book Information at:
www.cvm.org

Copyright © 1984–1995, 2021 by Christian Veterinary Mission

No part of this publication may be reproduced, stored in a retrieval system, or transmitted in any way by any means – electronic, mechanical, photocopy, recording, or otherwise – without the prior permission of the copyright holder, except as provided by USA copyright law.

Permission requests should be addressed to: vetbooks@cvm.org

OR

Christian Veterinary Mission
www.cvm.org

This is our Fourth Edition (Revised). We plan further revisions in the future. If you have comments, suggestions or information whereby this book could better meet the needs of your people, please write the author at Christian Veterinary Mission,
E-mail: vetbooks@cvm.org
Web site: www.cvm.org

Original Printing 1984
Revised Edition 1988
Third Edition 1994 (Revised)

Raising Healthy Animals Series

Every year, thousands of people around the world struggle to survive because they don't have the right knowledge, skills and resources to care for their animals. Christian Veterinary Mission (CVM) sends veterinary professionals to live and work alongside many of these people to encourage them and provide them with not only much needed veterinary expertise, but also the hope that is only found in Christ. CVM veterinarians build lasting relationships with individuals and communities, helping them be transformed through Christ's love.

CVM, in its effort to be meaningfully involved in work in the developing world, quickly found there was little appropriate educational material available. CVM set about developing basic resource materials in animal husbandry for farmers and agricultural workers. Apparently, they met a real need, as these books have been accepted throughout the developing nations of the world.

The series of books published by Christian Veterinary Mission includes the following in order of publication:

Raising Healthy Pigs *	Drugs and Their Usage
Raising Healthy Rabbits *	Where There Is No Animal Doctor
Raising Healthy Fish	Raising Healthy Horses
Raising Healthy Cattle	Zoonoses: Animal Diseases That Affect Humans
Raising Healthy Poultry *+	Raising Healthy Honey Bees
Raising Healthy Goats *	Slaughter and Preservation of Meat
Raising Healthy Sheep	Disease and Parasite Prevention in Farm Animals

[Also available in: * Spanish + French].

CVM fieldworkers have also developed specific training materials for the countries in which they work.

All of these books have been put together by Christian men and women; in a labor of love and service, for people in need throughout the world. It demonstrates dedication to their profession, service to humanity and a witness to their faith. We hope that they are a help to you in developing an appropriate livestock program to meet your needs. We pray God's blessing on their use.

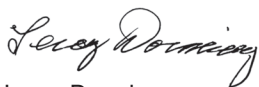

Leroy Dorminy
CVM Founder

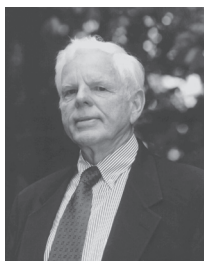

DEDICATION

In memory of my late parents, Carlyle W. Goodman, Sr and Neva Juleah Green Goodman, of, Sumter County, South Carolina, USA., who, by their example, were an inspiration to many, encouraging them to become involved in service to others.

To my family; my wife, Nancy Claire Goodman, my daughters; Claire Frances Goodman Watts, and Rebecca Sloan Goodman, and my son, David Earle Goodman, Jr. Without their understanding and support, this and previous editions of this book published by Christian Veterinary Mission (CVM), would not have been possible. This goes for other involvement with the ministry as well.

Many thanks, to these and others, who have unselfishly supported this important work of CVM.

BACKGROUND — NOTES ABOUT THE BOOK

This book was prepared by Christian Veterinary Missions as an aid to those working in areas where such information is limited. Hopefully, it will add to your efforts to improve the standard of living in your area by teaching livestock owners how to raise healthier, more efficient pigs. This book is the first of a series. Originally published in 1984 and revised in 1988, it has been well received and is now used in many areas of the world.

This book is written in discussion style with the intent of presenting a broad understanding of swine management. It contains a minimum of hard facts and tables, but makes extensive use of line drawings. Information contained in the book, adapted to local conditions, with a common sense approach to problem solving, will be of value to your particular area and situation.

Readers are encouraged to share comments and suggestions which might improve future revisions. In response to suggestions, we have added sections of basic treatments, restraint and handling, and a basic confinement system for small farmers. This edition includes additional recommendations on disease prevention and control, and more information on specific diseases.

Space does not permit in-depth coverage of every subject. A section on consulting by mail on special problems is included at the end of the book. It is frequently used by readers and we encourage its use.

We hope that you find this material helpful.

ABOUT THE AUTHOR

The author of this book, Dr. Earl Goodman, has had a lifetime interest and personal involvement in small-scale livestock production and Public Health. Dr. Goodman has lived and worked in a number of underdeveloped areas of the world.

He has lectured in Agricultural and Veterinary Colleges, and has given field demonstrations in rural areas of those countries. His extensive personal experience with small-scale swine production and rural veterinary practice provides useful knowledge and expertise, in disease control and swine health consulting.

He has served as Supervisor of Animal Health Programs for Clemson University Livestock-Poultry Health Department and Animal Diagnostic Laboratory.

Dr. Goodman and his family live in a small town in the coastal plains area of South Carolina, USA. They are involved in farming, community and church activities.

Dr. Goodman has had a long time involvement with the Christian Veterinary Missions, Publishers of this book.

TABLE OF CONTENTS

SECTION I—Introduction	9
SECTION II—A Healthy Environment.....	11
Living Conditions.....	12
Fencing, Tethering, Running Loose or Buildings.....	16
Sketches of Fencing.....	22
Buildings and Equipment	24
Feeders or Waterers.....	25
Farrowing Houses	30
SECTION III—Nutrition	36
Nutrition-Food and Water For Growth and Health.....	37
I. Carbohydrates and Fats	38
II. Protein	43
III. Vitamins.....	47
IV. Minerals	47
V. Water	52
VI. Methods of Feeding Pigs.....	52
Food Preparation for Pigs.....	54
Feeding a Balanced Ration	55
Feeding Pregnant Sows	56
Feeding the Nursing Sow	56
Feeding Baby Pigs	57
Feeding the Grower-Finishing Pig.....	57
Sample Rations	57
Special Notes	60
SECTION IV—Management Practices.....	62
Reproduction.....	63
Section on the Grower-Finisher (Fattening Animal)	74
SECTION V—Restraint and Handling Pigs.....	76
Restrain-Catching-Handling-Moving Pigs	77
SECTION VI—Understanding Disease and Parasite Prevention and Control.....	83
Siting.....	84
Pen and Pasture Rotation	84

Temporary	88
Birthing on Cleanest (Least Used Areas)	89
Importance of Providing Clean Food and Drinking Water	90
Other Considerations in Keeping Animals Healthy	91
SECTION VII—Health Problems in Pigs.....	93
General Consideration in Prevention of Health Problems in Pigs.....	94
SECTION VIII—A Basic Confinement System	126
Introduction	127
Waste Management.....	130
Health and Management Practices.....	131
SECTION IX—Consulting By Mail On Problems in Pigs	142
SECTION X—Acknowledgements	145

Section I

Introduction



Introduction

Pigs are grown in nearly all inhabited areas of the world except the Arctic, sub-Arctic areas, and some extreme desert climates. They are adaptable to wide ranges of climate and production systems—from the very primitive to the highly sophisticated.

Pigs can thrive on a variety of foodstuffs, making them very desirable as a source of protein and cooking fat. They can aid in land clearing, including slash-burn systems, by eating roots, seeds, vegetation, and seedlings of young trees. Their manure is a source of fertilizer.

Except in areas with religious or cultural taboos against eating pork, the flesh of pigs is a desirable source of food. It is very nutritious and safe to eat when a few basic sanitation and cooking practices outlined in this booklet are followed.

Pigs require a relatively small acreage, and their exceptional reproductive allows the establishment of a small herd in a short time, at minimal cost. A single pregnant female, properly managed, can soon supply food and income for an entire family.

Hopefully, this booklet will help you assist those in your area to do that.

Section II

A Healthy Environment

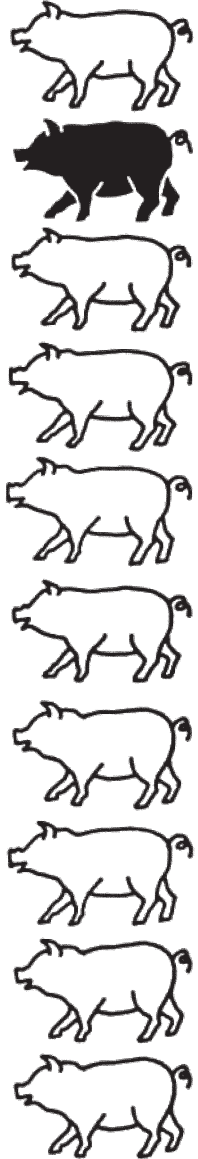

ENVIRONMENT PART I

Living Conditions

Environment (Living Conditions)

Protection from adverse weather conditions is an important consideration in raising pigs. Although they have adapted to wide variations of local climate, they still need protection from extreme heat and cold.

Swine suffer more from hot weather than any other livestock. They have no sweat glands in their skin. These provide a natural cooling system for other animals that can perspire and are cooled by the evaporation of this moisture from their skin. The heavier fat layer beneath the skin tends to hold body heat. For these reasons, it is necessary that we furnish protection from heat or allow pigs to use their native instincts to stay cool.

Protection from extreme heat can be just as important as protection from extreme cold. Prolonged exposure to bright sunshine or in poorly ventilated buildings may cause pigs to become overheated. This can bring on respiratory (colds and pneumonia) and reproductive (breeding) problems. Exposure to extreme cold, without protection from wind, rain, and snow often leads to severe respiratory problems in all ages, as well as slowed growth and reproductive problems.

Generally 10-27°C (50-80°F) is the best temperature range for adults. Baby pigs have a poorly developed temperature regulating response and need more warmth than do adults (around 27-32 °C, 80-90 °F, for the first three or four weeks). These are only rough guidelines. Native pigs adapt very well, over a period of time, to most extremes of local climate. They may need some protection, or allow them to use their natural instincts.

Sows, with their great maternal instincts, have a remarkable ability to protect their baby pigs from temperature extremes by farrowing in protected areas and making beds of dried vegetation. By using their natural instincts and their ability to adapt, plus a few basic management suggestions, healthy pigs can be grown almost anywhere that humans live. Pigs may survive extremes of weather without shelter; however, their health is often impaired and stunting, poor reproduction, and weak animals occur.

In areas where temperatures often drop below freezing, or chilling wind and rain occur, some type of temporary (movable) or permanent shelter will be needed. At the minimum, a roof and three sides are needed to protect against wind and rain. The open side should face the sun for warmth.

In tropical or subtropical areas, where temperatures are often above 27°C (80° F), some type of natural shade (tree cover), permanent or temporary (movable) shelter, will be needed. Thatch, straw, wood, or bamboo roofed, open-sided shelters are often all that is necessary,

If adequate natural shade is not available, Tin or other metal may be used for the roof, but tends to be hotter than other coverings. The framework can be made from discarded lumber, bamboo, or poles cut locally from the more rot and insect resistant trees.

On pastures and in dirt pens, sows and boars will need around 2 sq.m. (15 sq. ft.) of shelter, built with the roof sloped and approximately 1.5m (5 ft.) high. Sows with pigs need twice this much sheltered area. Growing-fattening animals on pasture or dirt pens need 1 sq.m. (10 sq. ft.) of sheltered area.

Temporary (movable) shelter is much to be preferred over permanent structures. They can be moved to prevent buildup of filth, which causes sanitation problems and leads to disease and parasite problems. They are less expensive and are easier to build.

Canvas or plastic sheets over a temporary framework can be used in emergencies, such as protecting a sow and her newborn baby pigs.

Pigs should be pastured on land that is well drained, with some tree cover for wind and shade protection. Mud wallows and low wet areas soon become unsanitary. They can be a source of disease and parasite problems. For this reason, pigs should be given shade and fresh water, otherwise, they should be moved often.

A wallow area where animals can escape extreme heat by laying in shallow water or mud, is a natural method of keeping animals cool. However, it should be used as a last resort, and only if other methods are not feasible because the poor sanitation leads to disease and parasite problems.

Running streams may bring disease germs from nearby farms. This is another reason why it is a good idea to keep pigs out of these areas and give them fresh water.

Pasture and pen rotation is almost a necessity. This is done, by moving pigs to an area not frequently used, allowing that area to rest. This goes a long way toward raising healthy pigs, free of disease and parasites. **Pens and pastures can be used again, 6-12 months later.**

If land is greatly limited, or a large number, of animals are being raised, permanent housing with floors may be necessary. Sanitation problems from the buildup of manure and filth, without adequate waste disposal systems, usually lead to serious health problems. Permanent housing should be built only as a last resort. Temporary shelters built for one or two adults, or several (one litter) small animals can be moved by a few people or may be built on pole runners and pulled to a clean area.

Pigs can be raised satisfactorily on a few acres if only a small amount is used at a time, and if the animals are frequently moved. ***It is almost certain that pens, pastures, or open land used continuously for as***

little as two years, will have developed health problems from disease or parasites, and should not be used again for 6-12 months for pigs.

More details on housing are given in the section on buildings and equipment. A basic confinement system is in the back of the book.

Often in your area there will be someone who has acquired experience over a long period of time, and has been able to successfully grow pigs. Careful observation of his methods may give you clues that you can pass along to others. You should contact any livestock specialists in your area for assistance (government workers or others).

In summary, the ideal pig living conditions are: high, well-drained land, with animals frequently moved to unused land and are allowed natural or artificial protection from weather extremes.

SPECIAL NOTE I: In some areas, vampire bats may bite animals, causing infections and spreading rabies. If they are a problem in your area, animals should be protected at night. Screened or boarded enclosures, or some source of light, such as candles, lamps, etc., usually prevent the problem. In such areas, pigs may be turned out during the day and protected at night.

SPECIAL NOTE II: Sows should farrow on the cleanest ground, (least used or longest without swine). Newborn pigs are very susceptible to disease. Infections and parasites do their most serious damage to pigs under 8-10 weeks of age.

THERE ARE FURTHER DETAILS IN LATER CHAPTERS.

SPECIAL NOTE III: Another important consideration; pigs be kept from having contact with **human and dog fecal waste**. This is to prevent the spread of certain parasites and diseases, that can be real problems. This is covered in more detail in ***the section on parasites.***

ENVIRONMENT PART II

The Big Decision:

Fencing, Tethering, Running Loose or Buildings

The Big Decision — Fencing, Tethering or Buildings

1. Totally Primitive—pigs allowed to run loose.
2. Tethering.
3. Pen or pasture with fencing and sheds.
4. Buildings.
5. Combinations of above.

Fencing, Tethering or Buildings

One of the most difficult decisions in pig production is to decide what type or combination of facilities to use. There are advantages and disadvantages to each.

Major considerations include the farmer's experience with pigs, cost and availability of building supplies and equipment, size of farm, climate, method of feeding and others.

1. **Primitive** — animals run loose, no buildings and no fences or only a few small pens.

- Advantages** — no cost for buildings and fences.
- less feed cost—animals forage for themselves with small amounts of other foods.
 - less experience with pigs needed.
 - less time needed to care for animals.

- Disadvantages** — wild animals may harm pigs, especially newborn.
- can't assist with farrowing problems and help when sick. Sows at farrowing time and sick animals are often hard to find.
 - animals may stray and come in contact with other pigs and become sick from disease.
 - may damage crops.
 - may come in contact with human and dog feces and ***develop parasite problems***. This would only be practical in isolated areas with no other farms closeby. However, it could be done in seasons when no crops are grown and animals are confined during the growing season.

2. **Tethering** — animals tied to control their movement.

- Advantages** — less costly than fences and still controls animals' movement.
- no unwanted crop damage.
 - no contact with human waste.
 - no contact with other pigs and less exposure to disease.

— keep pigs out of low wet areas where parasites and disease are a problem.

Disadvantages — takes time to train pigs to the tether. Start with younger animals.

— much time needed. Animals are usually moved to grazing area during daylight and brought back near the family at night. ***On hot days they can only graze early in the morning and late in the afternoon.***

Description of Tether Harness — It is basically a shoulder harness similar to a dog harness. It can be made from leather strapping or cloth webbing. It has to be long enough to encircle the body behind the front legs at the chest with one strap, and another around the neck in front of the front legs with short pieces to connect the two at the sides. Fit the harness over the pig's neck, cross it under the chest and wrap around the body. Attach the tether, preferably a chain (or rope) to the harness under the chest and tie to a tree, post or ground anchor. It has to be adjustable for growing pigs. Several sizes maybe needed.

Simple Neck Harness — ***Sometimes a simple neck harness is used.*** It can be made of the same material, and consists of one fixed strap around the neck, so it cannot tighten and choke the animal. It is then attached to the chain or rope. With this type neck harness, pigs should be trained from a very young age to get used to it. In most primitive situations, this type tether might be more practical than the one shown in the illustration.

2. **Pen or Pasture with Fencing and Shade Fences**

A. Woven Metal wire is very good, but is too expensive for most primitive farms. It is difficult to move, thus pens and pastures may be used too long with a build up of parasites (worms) and disease germs.

B. wooden fencing is less durable than metal, but because it is easily moved, it's use might encourage better sanitation practices.

C. **Barbed Wire Does Not Work Well for pigs.**

D. **Electric Wire** — is used on some areas very effectively, especially for temporary grazing, farrowing and other situations. Its limitations are: the need for a source of electricity, and the fact that it does not confine small pigs very well. Battery operated and solar units are available but very expensive.

E. Living Fence — some farmers use a living fence, of dense prickly cactus called "Kandelab". Other cactus type plants and dense prickly shrubs might be used. They might be planted beside other fences to keep small pigs inside.

- Fencing Advantages** — control movement of animals.
— assist at farrowing time and when sick.
— only minimal experience with pigs needed.

- Disadvantages** — cost of fence and shed, if materials have to be purchased.
— buildup of disease germs and parasites, unless moved often.

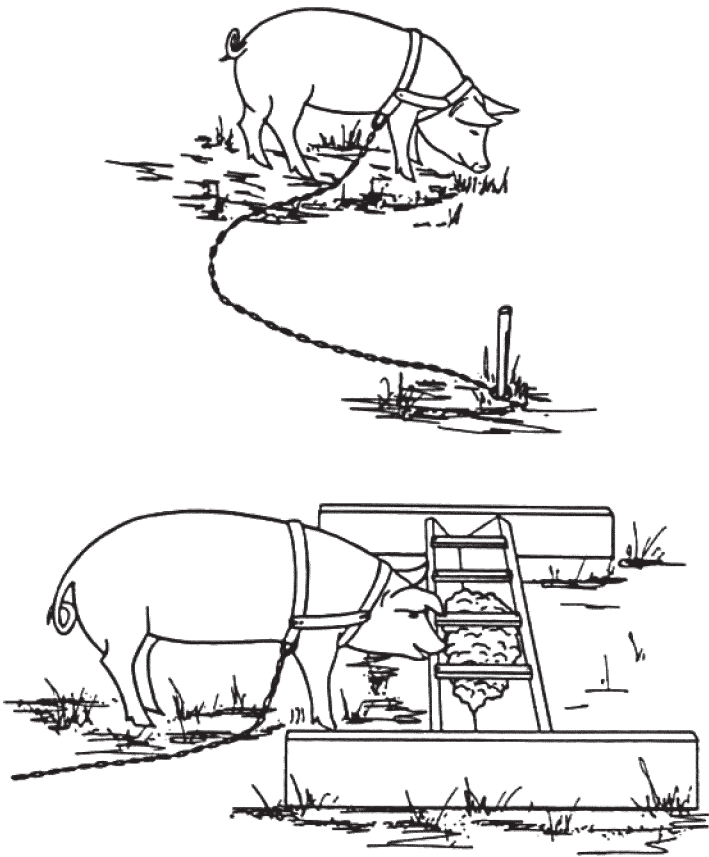

“Drawings of Use of Tether Harness on Pigs”

From: USDA Leaflet 537

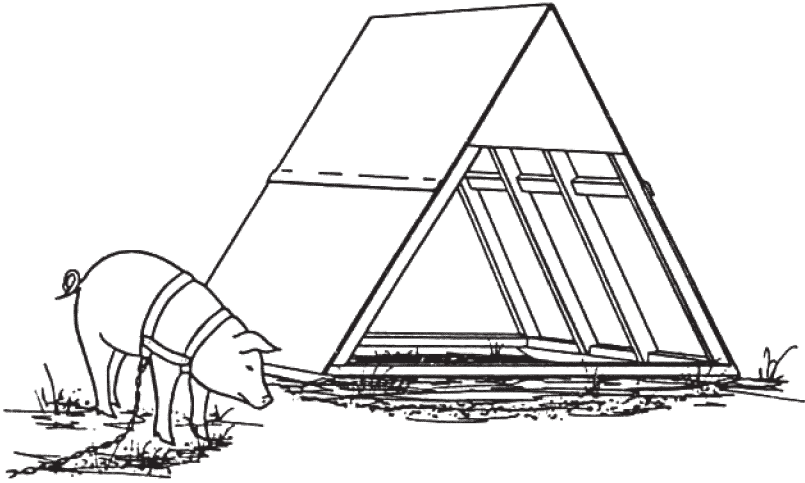

“Drawing of pig with Tether Harness and movable A-Frame Shed”

From: USDA Leaflet 537

Summary:

The most practical system for primitive farms is a **combination** of tethering and allowing pigs to run loose.

Example: — Tethering at farrowing time and growing season for crops.

— Run loose in non-crop season.

— This is probably the best combination in many cases.

Example: — Pen or enclosed pasture during farrowing time and crop growing season.

— Run loose during non-crop season.

— (This would be another combination)

Example: — Large pen or pasture most of the day, night.

— Tether animals for other grazing during part of the day.

Example: — Pen-Pasture during farrowing and baby pig time.

— Tether during crop season

— Loose during non-crop season.

4. **Buildings** — Other than temporary sheds as already described, there are a few reasons for using buildings in primitive pig production.

Advantages — Ease of handling animals when confined in small areas, especially at farrowing time and sickness.

— protection from extreme weather, **mainly cold weather.**

— less land used.

— fewer parasite problems

— less concern for theft of animals.

Disadvantages — cost of buildings and equipment.

— farmer needs more experience in raising pigs.

— sanitation problems from buildup of filth often lead to disease problems.

— baby pigs in buildings **with floors** will have a serious anemia problem unless precautions are taken. **See Notes in Baby Pig Section of Reproduction.**

— enclosed buildings are often too hot for animals' comfort and good health.

Note: There is a section at the back of this book that describes a basic confinement system in detail.

SKETCHES OF FENCING

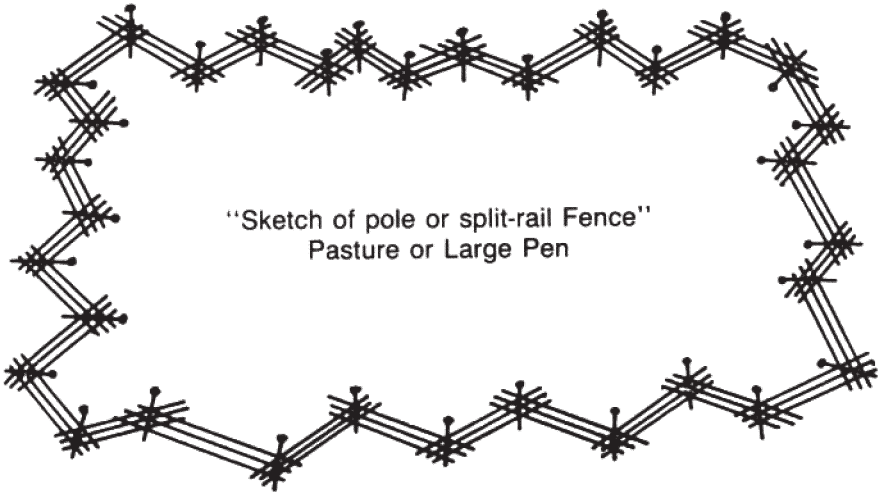

This uses long poles or split-rails around 3 m. (10 ft.) long. They are laid horizontally and overlap each other at the ends. For maximum strength the ends must cross at an angle. An upright pole in the angle adds more strength. The poles may be attached to each other with nails, wire, or strong vines. For many reasons, this type fencing is often used in primitive livestock production.

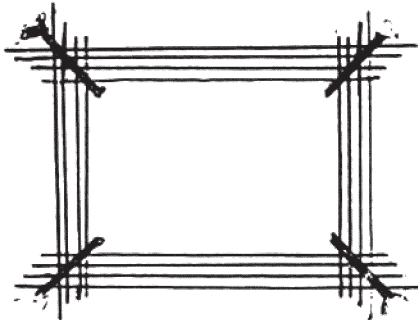

An example of a small square shaped pen that is one rail long on each side. They have many uses, such as separating sows from baby pigs at weaning. They can effectively confine adult animals. A strong upright **post** in each corner greatly strengthens the pen; especially if placed in a hole.

Note: The bottom rail should be placed at or below ground level to keep baby pigs confined.

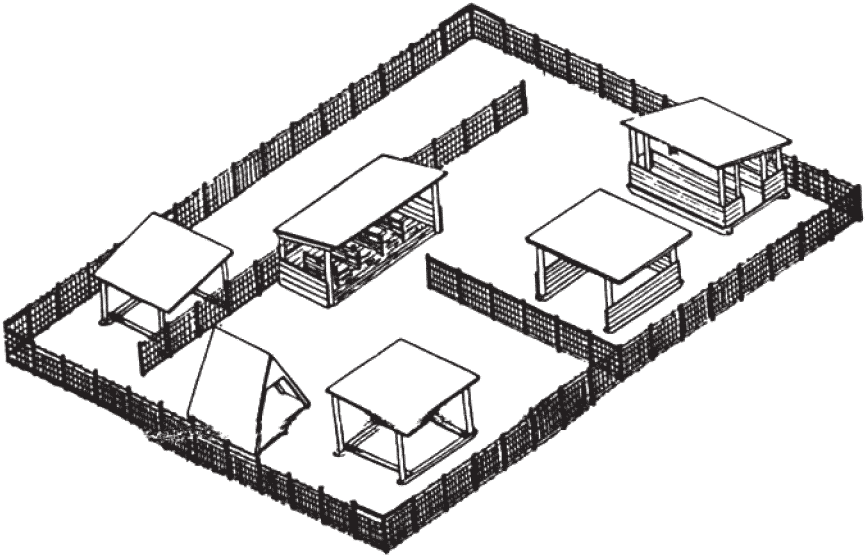
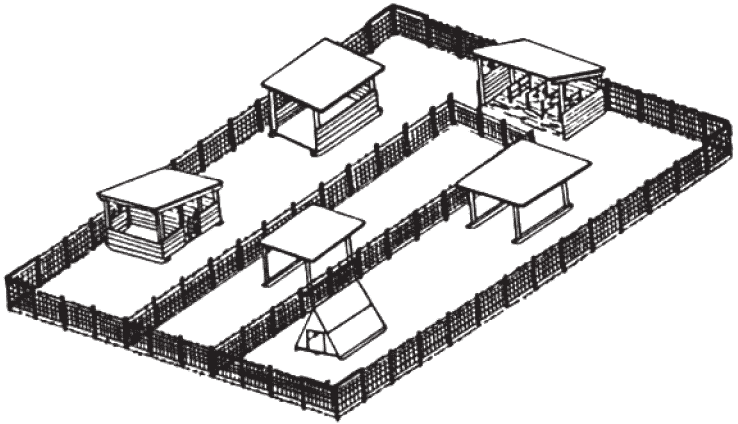

From Tuskegee Univ.Cir. TI-AS-14B 6:79

These drawings illustrate a practical layout for a small pig production unit. ***Always keep in mind, that pasture and pen rotation is an absolute necessity, in raising healthy pigs.***

Note: Read the very important notes on siting-location of the livestock unit, pasture and pen rotation, use of temporary-movable buildings etc. in the section VI on Disease and parasite Prevention and control.

ENVIRONMENT PART III

Buildings and Equipment

FEEDERS OR WATERERS

PORTABLE FEED BUNKS

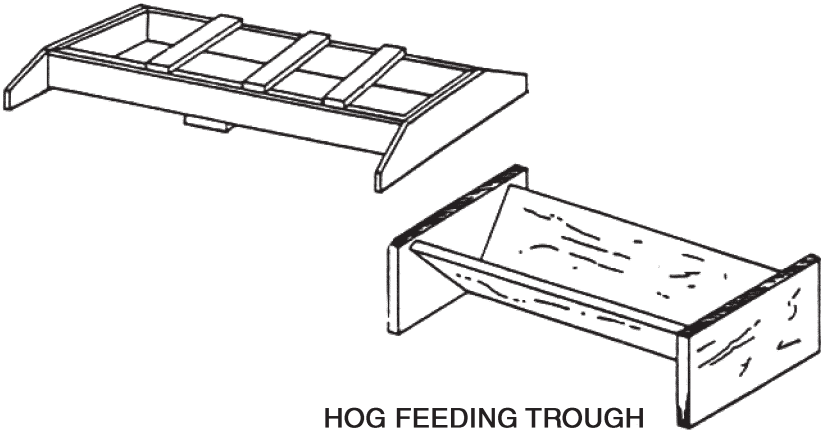

FEED OR WATER TROUGH FROM OLD TRACTOR TIRE OR TRUCK TIRE

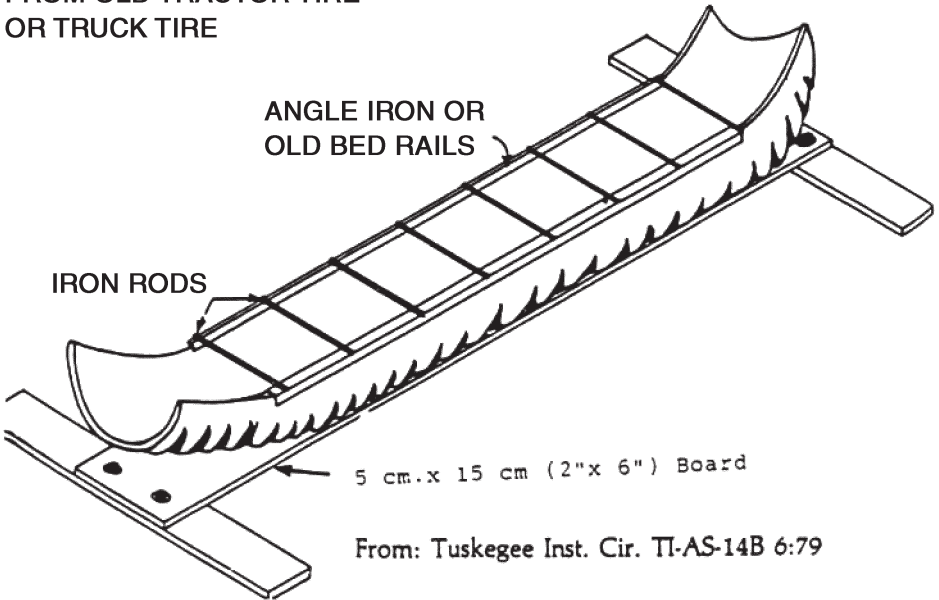

The following drawings illustrate the use of used tires for feed or water troughs. Truck or small tractor tires work best because the walls are stronger and stay apart better. They are difficult to clean and often become unsanitary; they would be best used in a temporary situation or as a last resort.

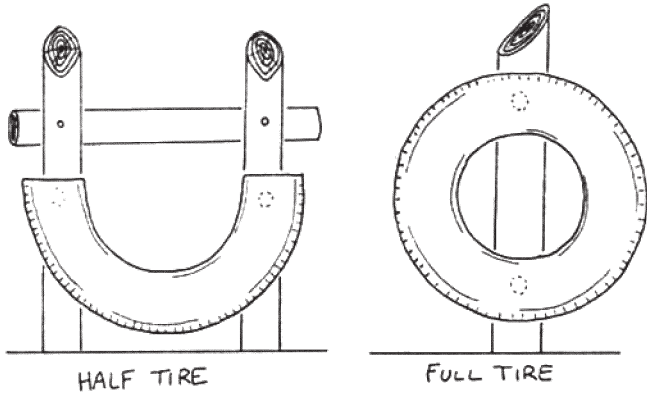

"Drawings of Feed and Water Troughs for Pigs"

Adapted from Clemson University Agr. Eng. Circular 205

NOTE: Other drawings of feed and water troughs are shown at the end of Section VIII—Basic Confinement System.

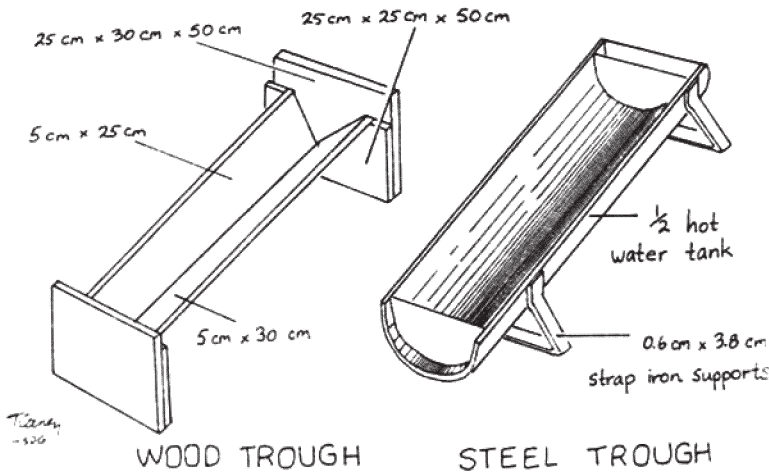

FEEDERS OR WATERERS

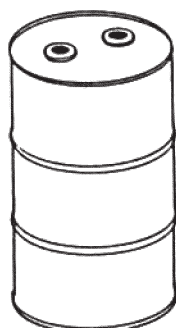

FEED OR WATER TROUGHS
FROM RECYCLED OIL
DRUM 209 Liters
(55 gallons)

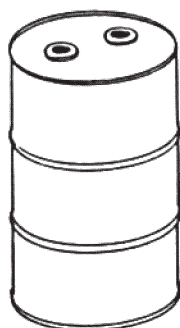
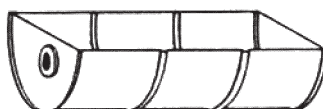
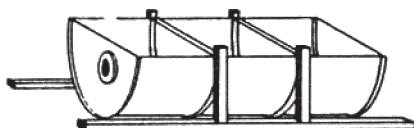
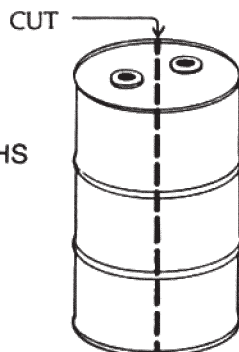

OLD OIL DRUM
CUT IN THIRDS

Note: Caution:

Do not use old chemical containers. They often contain harmful residues!

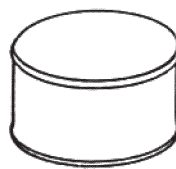
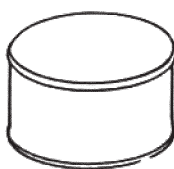
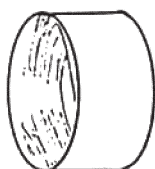
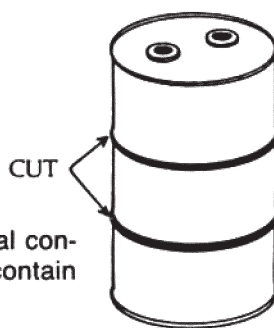

From Tuskegee Institute Cir. TI-AS-14B 6:79

Examples of concrete feeders and waterers are shown in the section on confinement in the back of the book.

Adapted from:

Plan For a Home Constructed Self-Feeder, With Feeding Space on One Side. The hogs may feed from this feeder by raising the doors that are hinged at the back.

(Courtesy—Agricultural Extension Service, State College, Mississippi)

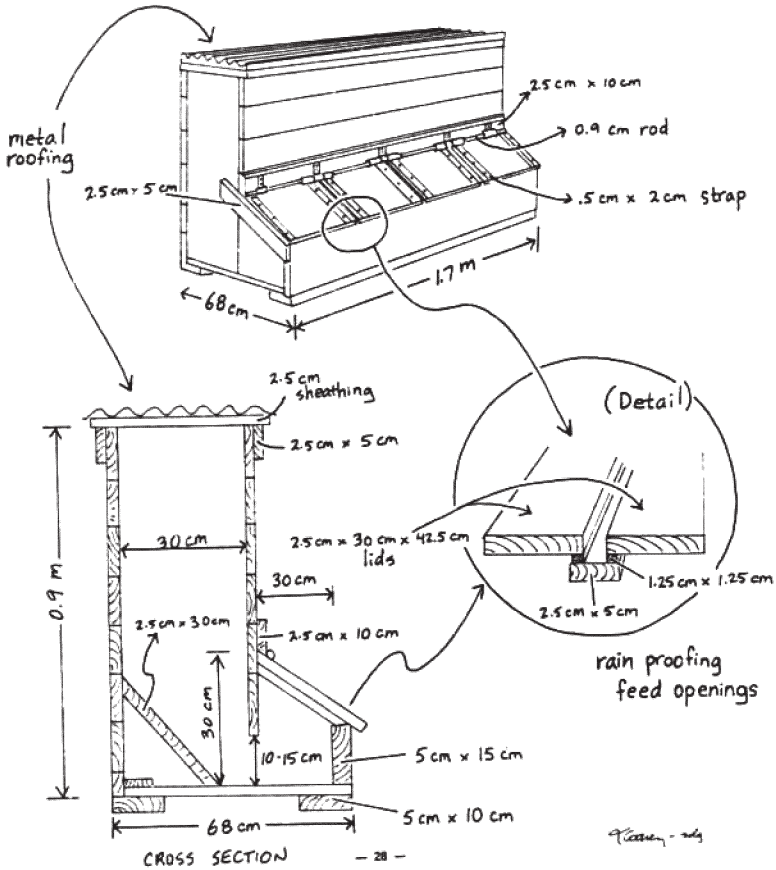

Adapted from

Plan For a Home Constructed Self-Feeder With Feeding Space of Each Side. (Top) Perspective. (Bottom) Cross-Section.

(Courtesy—Agricultural Extension Service, State College, Mississippi)

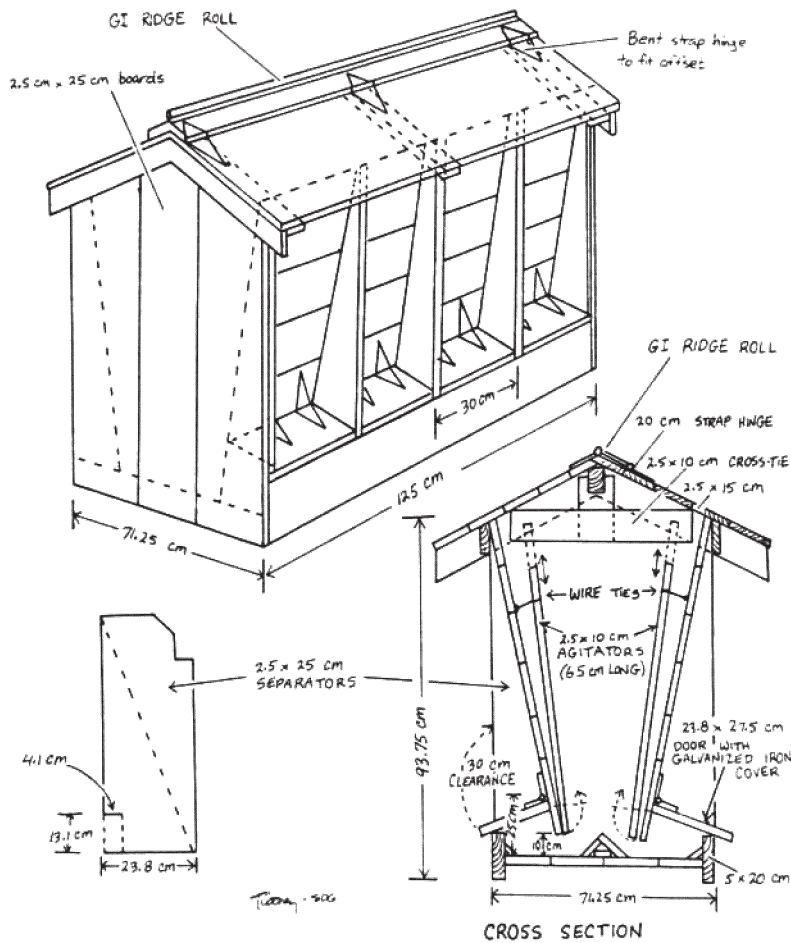

Farrowing Houses

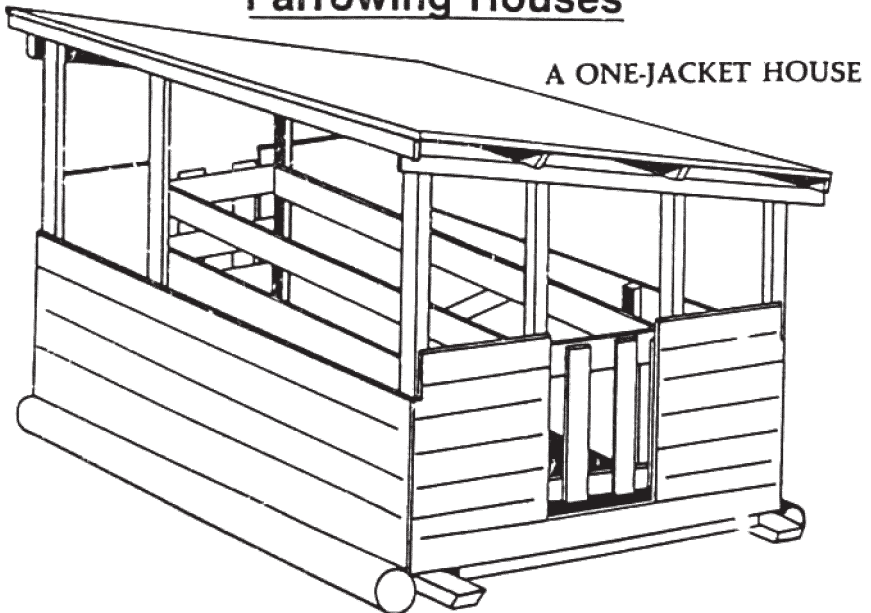

A ONE-JACKET HOUSE

CROSS SECTION

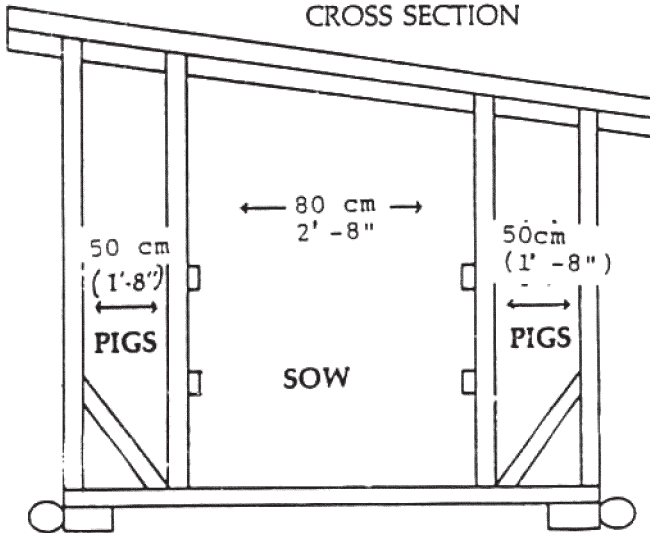

From: Tuskegee Ins. Cir. TI-AS-14B 6:79

NOTE: If floor boards are spaced 2.5 cm (one inch) apart, sanitation is much improved as urine and feces can fall to the ground. If the unit is moved after each farrowing and weaning, we leave feces and filth behind which greatly aid in sanitation and improved health.

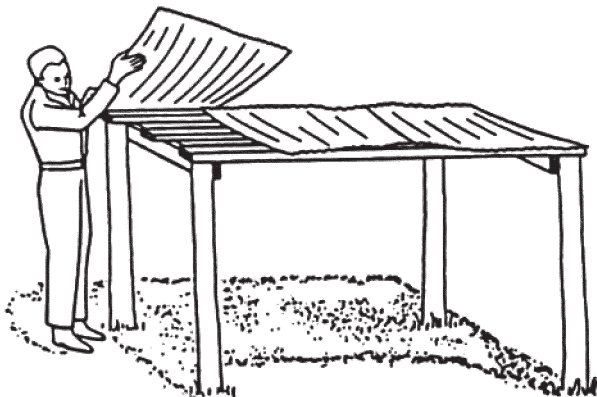

Above drawing of Temporary Shed made from poles and scrap building material. Thatch or straw would also work well if roof were more steep.

From USDA Leaflet 537.

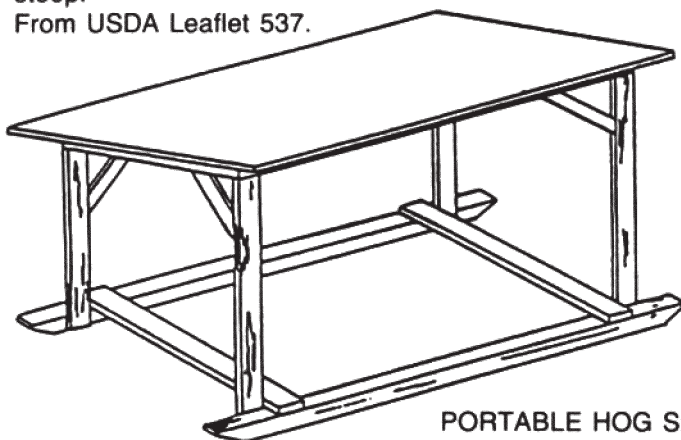

PORTABLE HOG SHADE

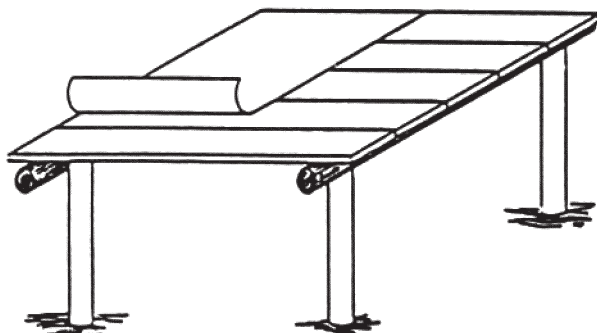

STATIONARY HOG SHELTER

From: Tuskegee Int.. Cir. TI-AS-14B 6:79

A-TYPE HOG HOUSE

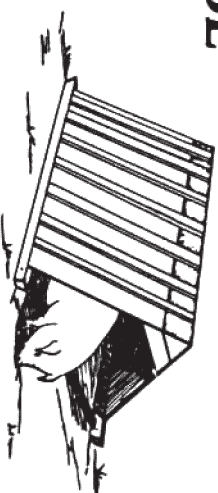

BILL OF MATERIALS

- 2 - 2"X 6"X 8' (5cm X 15cm X 240cm) RUNNERS
- 7 - 1"X 6"X 8' (2.5cm X 15cm X 240cm) BRACES
- 10 - 1"X 3"X 12' (2.5cm X 7.5cm X 360cm) BATTENS & CLEATS
- 10 - 1"X 8"X 12' (2.5cm X 20cm X 360cm) SIDING
- 1 - 2"X 4"X 10' (5cm X 10cm X 300cm) GUARD RAIL.
- 2 (1kg) LBS. 8d COMMON NAILS
- 1 (1/2kg) LB. 6d COMMON NAILS
- 1 PC 24" (62.5cm) TAR PAPER 7' (210cm) LONG

PREPARED BY

G.H. STEWART, LEADER
AGRICULTURAL ENGINEERING EXTENSION
WORK

AND

A.L. DURANT
EXTENSION LIVESTOCK SPECIALIST
COOPERATING

CLEMSON AGRICULTURAL COLLEGE

Cooperating with
UNITED STATES DEPARTMENT OF AGRICULTURE
EXTENSION SERVICE

D.W. Watkins, Director
Clemson, South Carolina

DISTRIBUTED IN FURTHERANCE OF THE ACTS OF CONGRESS
OF MAY 8 AND JUNE 30, 1914.

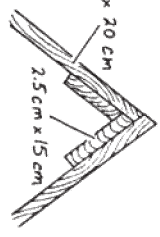
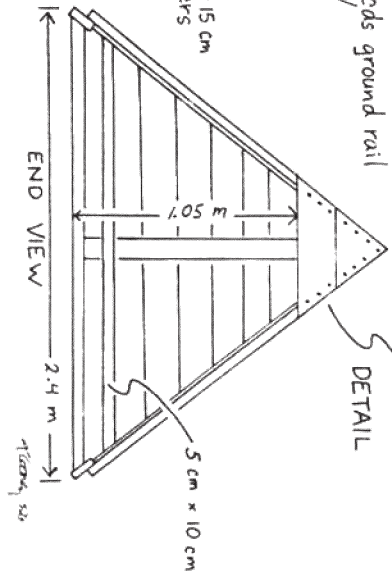
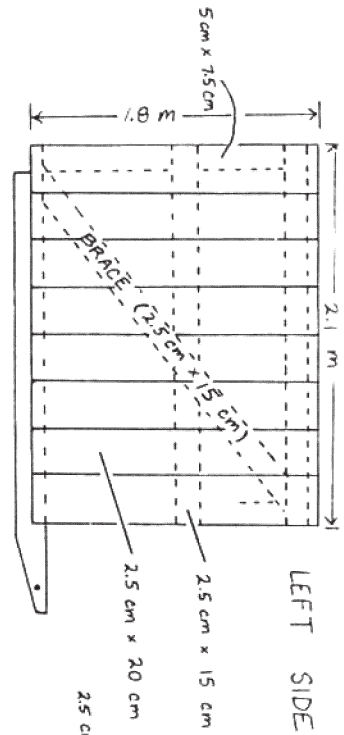
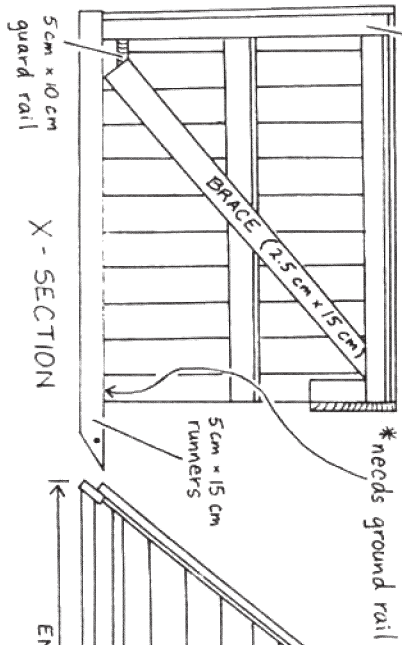
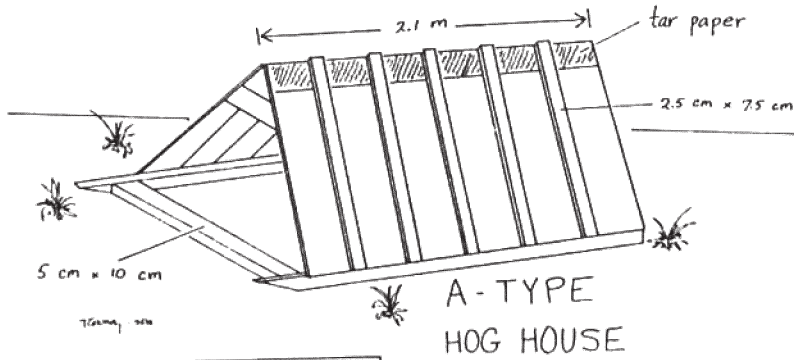

A-TYPE HOG HOUSE

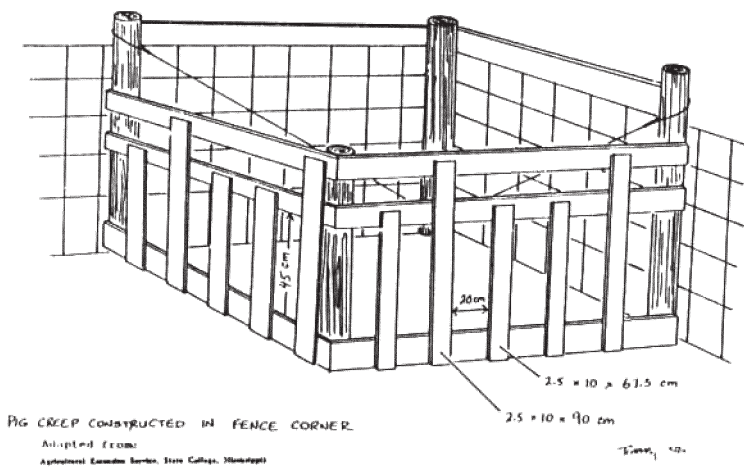
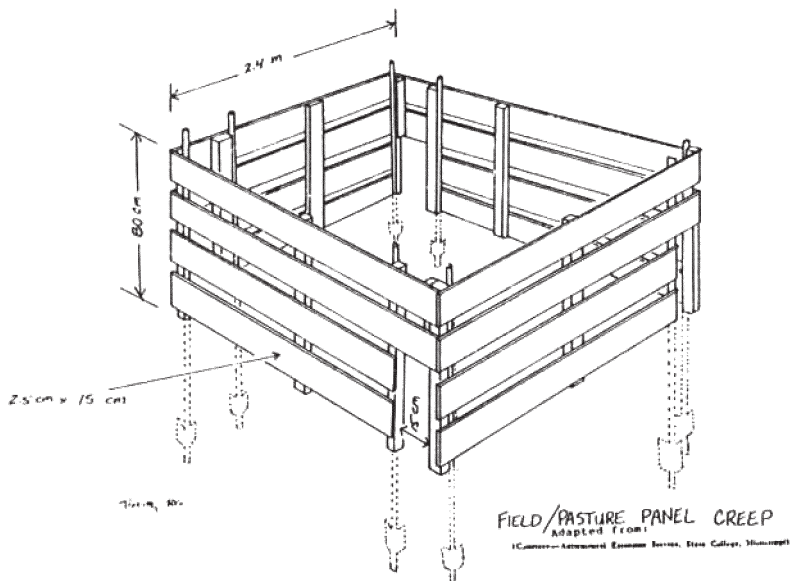

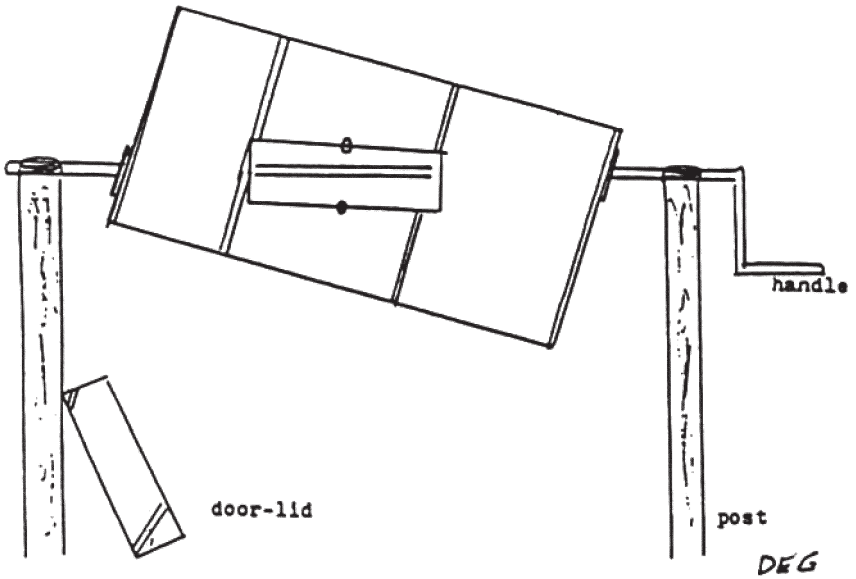

90 kg (200 pound) feed mixer made from a 170 or 350 liter (44 or 66 gallon) drum, shown with door off for filling or unloading.

NOTE: Some type of simple latch is needed to keep the door secured when mixing.

CAUTION: DO NOT USE DRUMS PREVIOUSLY USED FOR CHEMICALS.

Section III

Nutrition

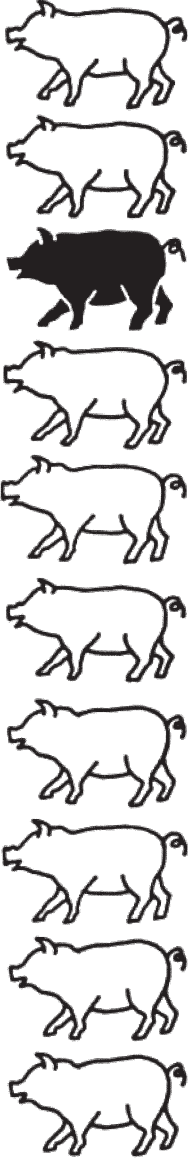

Nutrition-Food and Water For Growth and Health

In this booklet, we will greatly emphasize nutrition because feed is the greatest cost in pig production. So many aspects of an animal's health are affected by nutrition. Pigs are able to consume and often thrive on a wide variety of foodstuffs. Many of these foods are in a surplus, seasonally; are very inexpensive in certain areas; or, are not nutritious or appetizing for humans. Consequently, they may be wasted, if not fed to pigs. There are many times when grain and purchased ingredients, fed along with other products, will result in a great increase in protein and cooking fat. This protein and cooking fat would probably not be available, if it were not for some of the unique characteristics of pigs.

Like humans, pigs have a simple stomach of relatively small size. Since pigs are omnivorous (like man), they are able to utilize food of both animal and plant origin. This gives us many options in feeding pigs that we do not have in feeding cattle, sheep, and goats.

Pigs are able to utilize forages, grass, and other grazing, much better than is generally believed. This gives us options that help extend other foodstuffs in the diet.

Nutritional needs of the animal are influenced by size, age, pregnancy, nursing pigs, climate, soil type, and many other factors, such as confinement in buildings with floors. These nutrition suggestions are offered as information only. ***They should be used on the basis of the animal's needs, with the realization that local conditions and the owner's circumstances will dictate a great degree of flexibility in feeding pigs.*** For this reason, the author has extensively researched the subject to find as many foodstuffs that pigs can consume. Visits to existing hog farmers in your area may help you discover other satisfactory foodstuffs for pigs.

The key to pig nutrition is understanding that different classes of foods must be combined for a balanced ration. No one feed provides all required nutrients.

There are five classes of feeds for hogs:

Carbohydrates and fats: These are mainly grains, but include dried (and fresh) fruit, yams, potatoes, molasses, and fats. Vegetables and garbage are included, but are less desirable. Foods in this group give energy which is used daily in body processes, stored as fat, and used for milk production. They make up around 75-80% of the total pig diet.

2. **Protein:** This is supplied by a number of animal and fish by-products, and oil seeds. Good grazing supplies much protein. Grains contain a small amount. Protein provides for growth and builds tissues (muscle and lean meat).

3. **Minerals (including salt):** These are supplied by sources such as, ground limestone, steamed bone meal, and salt. These are necessary for bone and tissue growth, and for body functions.

4. **Vitamins:** These are needed in small amounts for growth, reproduction, and body functions. They are **necessary** for good health. Vitamins are mainly supplied by good grazing, but small amounts come from protein sources and fresh fruits and vegetables.

5. **Water:** A fresh, plentiful, constant source of water is essential for good health.

I. Carbohydrates and Fats:

A. **Grain:** In areas where corn can be efficiently produced, it is a staple of hog rations. Any grain can be fed, as well as grain by-products and substitutes. Often grain is expensive or not available locally. Small amounts, used along with other inexpensive ingredients, will greatly extend them and will help balance the ration. This method can be cost effective. It can increase the protein and cooking fat available to humans. In isolated areas where transportation of farm products is difficult, meat and animals are often more easily sold than grain.

1. **Corn:** Corn is an ideal pig feed, but, **as with all grain products**, needs to be balanced with extra protein and minerals, for best results. Yellow corn has more vitamins and is preferred.

2. **Wheat:** This grain is similar to corn and is an ideal hog feed. Cost and availability, however, mean that little is used as pig feed (it should also be balanced with protein and minerals.)

3. **Oats:** This is a good hog feed and it is less expensive than wheat. Because of its high fiber content, it is better for adults than young animals. Hulled oats are a good feed for young pigs.

4. **Barley:** It is almost as good as corn, **but must be crushed or ground.**

5. **Rye:** If ground or crushed rye is a satisfactory hog feed.

6. **Grain Sorghums:** These include milo, millet, kafir, etc. They are similar to corn in feed value to pigs, if crushed or ground.

7. **Triticale:** A relatively new hybrid, is a cross between wheat and rye and it can be used satisfactory as pig feed. Except for short periods, it should not constitute over 50% of the total diet. Recent research has shown, that certain **ergot-free** varieties of triticale perform as well or better than corn, when fed as the only source of grain for hogs.

8. **Wheat Bran and Wheat Middlings:** These are similar in feed value to wheat and can be fed to pigs, if available, at a reasonable cost. These are better fed to animals over 40 kg (100 pounds) and larger. They should not make up more than one-fourth of the total ration, except for short periods. These are milling by-products.

9. **Other grain or feed milling by-products** including floor sweepings, may be fed to pigs. There is an element of risk if other chemicals are stored in the same building.

NOTE: All of these grains, except corn, should be ground, crushed, cracked, or soaked in water, to insure maximum utilization as pig feed. Except when used for baby pigs, most varieties of dent corn may be fed as whole grain.

(All varieties of flint corn have extremely hard seed coats which may require cracking or softening to improve palatability and consumption. Hogs fed excessively hard corn may go off feed in the absence of evident disease. Examination of the mouth will show tender, swollen, cracked or bleeding gums).

See ***Details*** in the section on ***Food Preparation***.

B. Rice Products

1. **Rice:** Rough or paddy type is a good pig feed, but only, if ground or cooked. It is better used with older animals. Cost and availability limit its use in pigs, except for special circumstances. It can be used to extend other inexpensive products in order to produce protein and fat. Older hogs do well on rice stubble.

2. **Rice Bran and Polish:** A good pig feed, if mixed with other grain and a little protein. Do not feed as the only carbohydrate source except for short periods. The high fat content causes rancidity to develop quickly.

C. **Grain Substitutes:** These are best used to replace part of the grain, but cannot be used as the only source. As with other products, they need to be balanced with minerals, a little protein, and grazing or cut forage.

1. **Potatoes:** Cull or surplus potatoes are occasionally fed to pigs. If cooked they can replace part of the grain in the diet.

Note: Sprouts may be dangerous. Remove before feeding. Dehydrated potatoes also work well.

2. Yams (sweet potatoes): These are a good grain substitute. Do not feed as the only carbohydrate source except for short periods of time. ***Do not feed molded or rotten potatoes or sprouts.*** If yams are not grown in your areas, suggest it be tried. Cooking improves their value. It takes 3-4 pounds to replace a pound of corn. Sweet potato leaves and stems are a good source of protein, since they contain 20-30% protein.

3. **Manioc (Cassava-Manihot-Yucca)**: These can be used as a grain substitute. ***It can be poisonous to humans and animals.*** Heavy peeling and boiling seems to prevent this problem. In some areas, this is done by cutting them up and air drying for several days. A practical guideline is to prepare it as is done for human food. This is a food that seems to be cheaply and easily grown in a warm climate. It probably should receive more attention as a pig food.

4. **Cassava Meal**: A manufactured product which is a satisfactory grain-substitute in pigs, if available at a reasonable cost.

5. **Molasses**: Can replace part (1/3) of the grain, but should not be used as the only carbohydrate except for short periods. Molasses should ***not*** make up more than 10% of the diet of young pigs, 20%-to-30% in growing animals. Cane molasses are best, beet molasses fair, and citrus molasses are least desirable.

Cane juice is another carbohydrate-energy source that has been used in pigs. It must be utilized within 8 hours or it ferments. Sodium benzoate at 9.15% V/V (approx. 300 grams in 205 L. of cane juice) conserves the juice for 7 days. It is an excellent source of energy and is appetizing to pigs. Pigs have been fattened on it alone. Weight gains were good. However, a source of protein, vitamins and minerals should be given.

6. **Sugar**: Same as for molasses.

7. **Tubers**: Root crops, artichokes, beets, and turnips, and any other root vegetable, eaten by humans, is a satisfactory pig feed. These are not highly nutritious, but pigs like them. They can extend the diet somewhat. Carrots are better than any others.

8. **Cull Vegetables**: (overripe or surplus): Cucumbers, watermelon, tomatoes, pumpkin, lettuce, cabbage, squash, and others, locally available, are not highly nutritious, but can extend the diet. They should not be the only food for nursing sows and young animals. They are better used in larger growing animals.

Tomato by-products are available as a result of the tomato paste industry. The by-products include the skin and the seeds. These by-products ferment or rot quickly, but if fed immediately, have a 25% level of protein (DM basis). They can be used up to 20% in the diet.

9. **Cull Fruits**: (overripe or surplus): Coconut, ripe bananas, pineapple bran avocado (without seeds), pears, apples, peaches papaya, and breadfruit are satisfactory for up to 1/3 of the diet, or higher for short periods. They should not be the only food for nursing sows and young animals, as they are too low in energy supply. Any other fruit available locally should be looked into as pig feed. ***Bananas*** can be utilized in several forms, but are more appetizing if allowed to ripen. Green bananas are somewhat bitter and pigs will eat less of them than they will eat if ripe. Ripe bananas may be fed whole with peelings. Green

bananas may be made more appetizing by cooking. Bananas are often in surplus and may be available free, or at a very low cost. In such areas, they should receive more attention as food for pigs. Bananas and breadfruit are among the best grain substitutes for pigs.

Note: Vegetables, potatoes, and fruit should be cut into small pieces for better digestion, and to prevent choking.

10. **Dried Fruit:** Cull raisins, dried figs, prunes, dates, apples, etc., can be fed to pigs. They should be limited to 1/3 of the diet, except for short periods. This is one method of preserving surplus or inexpensive food for later use, when it is out of season.

11. **Citrus Fruit and Pulp:** There is often a surplus of this at harvest time. It can prove to be an inexpensive feed as culls may be free. Information for other fruit applies here. They can be fed with the peelings. Those with a sweeter taste, such as oranges or tangerines, are preferred over lemons, limes, and grapefruits. Beet pulp is almost the same in food value, for a pig.

12. **Kiawa Bean Meal:** If dried and ground or crushed, this is a satisfactory pig feed for up to 1/3 of the ration. It is high in fiber and it is best fed to non-nursing animals.

13. **Copra:** This is coconut oil meal. It is a satisfactory carbohydrate-grain replacer for up to 1/3 of the diet. It is not very appetizing to pigs and should be mixed with other food for better results. Molasses works well with copra.

14. **Babassu Oil Meal:** This is a manufacturing by-product of the Brazilian palm. It is similar in food value to that of Copra for pigs.

15. **Tamarind Seed:** It has been fed satisfactorily in India as a grain-carbohydrate source, although details are not available.

16. **Incubator Waste Eggs:** This is a good source for pigs that is often available around egg hatcheries. They are a reasonably satisfactory food for pigs, but only if cooked and in small amounts.

Caution: No grain or seed of any kind (including oil seeds such as peanut, soybean, and cottonseed), which has been treated with **chemicals for planting**, should be fed to animals or humans. **All seed treatment chemicals are harmful.**

17. **Baggasse:** This is sugar cane pulp, a manufacturing by-product. While not a very desirable grain substitute, it can be used in small amounts, (not over 15%) in the ration of larger growing animals. (See Sample Ration 13). It is best used with molasses. It has very little feed value for pigs and should only be used as a last resort.

D. **Waste Kitchen Fat:** Lard and tallow, cooking oils. All of these are good energy sources and work well in a swine ration. They should not be the only energy source. Fat stimulates nursing sows to give more milk that is richer in fat. It should be supplemented with other carbohydrates, protein and minerals. Food grade vegetable oils, such as peanut, soybean, and sunflower, works well.

In the tropics, feed should not be stored for long periods of time. This is especially true if oil is mixed in it, because the feed spoils quickly. In addition, oil should only be top-dressed and not mixed in feed that will be stored in hot temperatures.

E. **Bakery Waste:** Stale bread, dough, cake, etc., are occasionally available free or are inexpensive. They are often not appealing to humans or, are a surplus. They are similar in food value to grain and can replace it. Protein and minerals are needed to balance them. If very dry, they should be moistened.

Caution: Do not feed moldy products and always remove plastic and paper wrappers

F. **Garbage Feeding:** Garbage can be a grain substitute carbohydrate source. It is usually animal or vegetable source of food discarded from the human supply. Business, institutional and military garbage is far superior to household garbage, though both are satisfactorily fed. As with any grain-carbohydrate source, protein and minerals should also be fed. Because of poor nutrient balance, garbage alone should not be fed to the very young or nursing adults; it is best fed to growing animals. Because *it often contains meat and bone scraps, it may spread disease and parasites (Trichina and Tapeworms) that affect humans and animals. Boiling for 30 minutes is considered an adequate safeguard.* It improves the food by blending it and softening it. As a last resort, if cooking is impossible, try to remove meat and bone scraps or cook these separately. Remove plastic, paper, metal foil, etc.

Particular attention should be paid to slaughter house waste as a source of disease and parasites. ***Always cook these well before feeding.*** Good quality garbage with meat scraps may be fed without added protein to growing animals; however, they will grow faster and healthier with more protein. Garbage always needs to be supplemented with minerals, including salt. Garbage alone is not a satisfactory food for pigs under 8-10 weeks old. In order to do well, they need some regular carbohydrate-grain produce and added protein. ***Feeding household food waste to pigs is often a recommended practice in primitive situations.***

Animals confined in a small area and fed garbage will greatly benefit, ***if freshly cut green grazing food is also fed, to supply vitamins.***

Environmental Note: Because of many factors, garbage feeding soon becomes unsanitary and pigs generally suffer from more health and ***disease problems.*** Rotation of pens and pastures, on at least a 6-12 month system, is a great help in growing healthier animals.

To keep the environment healthier always place garbage in troughs; not on the ground. Concrete feed troughs, as shown in the section on confinement in the back of this book, are good to use.

G. **Forages-Green Grazing:** Grazing is an inexpensive source of nutrients that is usually available. It should be utilized, if at all possible, wherever swine are grown. In many areas, it is available year around. In non-nursing adults, it can replace part of the carbohydrate-grain and protein. Grazing is especially helpful for pregnant animals. It is almost a necessity, unless a well-balanced highly nutritious diet is fed. Legumes, such as clover, alfalfa and others that are high in protein, do well with no added nitrogen fertilizer. If local conditions are suitable, they should be grown even if in small patches. ***However, any (non-poisonous) green vegetation is helpful.***

If grazing is of high quality or in limited supply, it may be better to ***cut it and bring it to animals***, rather than damage it by grazing. Any excess can be dried like hay for further use.

A source of forages-greens is almost a necessity, if we keep animals confined in floored pens. This is to help provide a source of vitamins.

In many countries, local experimentation has developed greatly improved strains of local grasses, that are more nutritious and resistant to disease and insects. Imported grasses may have been introduced that are much better than local forage. In either case, seeds or cuttings of these should be started from the original planting.

While commercial fertilizer is often too expensive, or transportation is too costly, there may be some situations where cost will allow their use. Yields are greatly increased with fertilization and foods are much more nutritious. In many cases, small amounts of fertilizer will increase yields enough to be cost-effective. In other areas, soil testing will have indicated that single ingredients, such as phosphorus or potassium alone, will greatly help. They are much less expensive than complete fertilizers.

Bird and animal manure can be a source of fertilization.

Grazing, with access to wooded areas, allows swine to supplement their diet with grubs, earthworms, roots, seeds, acorns, berries and occasional small rodents.

II. Protein:

Grain and grain substitutes do not contain sufficient protein to satisfy the needs of swine. Therefore, some feed high in protein needs to be added when possible. Failure to do this causes slowed growth, stunting and many health problems.

Although commercial products are costly, there are often local sources of some type of protein which can be grown or purchased, at a reasonable cost. The numerous possibilities listed here prove that to be true.

A. Plant Sources of Protein:

1 Soybean Meal is 40-44% protein and is the ideal pig plant protein. **As with all plant protein sources, it should be supplemented with vitamins and minerals. It should not be over 1/2 of total ration. Whole soybeans can also be used.** Cooking soybeans for 30 minutes at 280°F or 138°C will destroy a chemical that interferes with digestion and **should be done**. Any cooking, such as parching or boiling, is a big help. Soybean meal is safe without cooking again.

2. Peanut Meal is 47% protein and is a good protein source. It is a better ration if some meat or fish protein is also fed. Peanuts can be fed raw to pigs and in the hull.

3. Linseed (Flax) Meal is 35% protein. Information for peanut meal applies here but should only be fed in limited amounts or a short time. It should not make up more than 1/3 of the added protein. It has a laxative affect and small amounts are good for sows.

4. Cottonseed Oil Meal is 35% protein, but unless specially processed, it is **dangerous to swine** because of a chemical called, gossypol. It is mentioned here, because cotton is grown in many areas and may be available at low cost. **If care is used** — small amounts, **not over 10%** of a normal ration may be fed, if animals are closely observed. The best use of cottonseed oil meal, in pig rations, is to extend or supplement other sources of protein.

5. Copra (Coconut Meal) is 21 % protein and rates as a protein and carbohydrate-grain source. It is better if a small amount of animal-meat or fish protein is also fed.

6. Field Peas is 23% protein and are a good source of protein for swine. They are usually grazed but they are more efficient and less waste, if hand picked. They may be dried for later use and cooked for swine. They supply carbohydrate as well. Since they require little fertilizer, and in many areas can be grown year-round, they should receive more attention, as a swine feed. They yield well on small patches and also a good human food. **The dried peavine bush makes excellent hay.**

7. Navy, Lima and Other Edible Beans are 23% protein. They supply protein and energy. They have to be cooked or they are toxic (poisonous). Salt can be added to make more appetizing.

Caution: Hulls of some beans, if wilted, are poisonous and should not be fed. Caution — Raw velvet beans are not safe for pigs and they are not totally safe even if cooked.

8. Alfalfa: (Green) or Hay (Chopped Fine) is an excellent source of protein, vitamins and minerals for swine. It is usually high priced but even in small amounts it is an excellent swine feed at up to 10% of total ration. Newer varieties show promise of being grown in many areas not formerly suitable. I suggest that it be tried in your area.

9. **Sunflower Seeds:** They can be a source of protein for swine, though not as suitable as others. It is a better feed for adults since it is high in fiber. Can be fed to all ages except baby pigs.

Sunflower Meal: It contains 25-45% protein. It is better than seeds. This can be satisfactory for all ages.

10. **Safflower Meal:** It is low in protein (20%) but it is a fair protein source for up to 10% of total diet.

11. **Sesame Meal:** 44% protein. If this is used as the protein source, some animal protein is also needed.

12. **Feather Meal:** (By-product of poultry processing). It is not a good protein source for swine, but it is available in some areas and should be used if inexpensive. It is best used to extend other protein.

13. **Brewers Grain:** (By-product of beer processing and distillers by-product of alcohol production). It is a satisfactory source of protein for swine, if available and reasonably priced. They have the same limitations as the grain from which they were produced.

14. **Tree leaves and stems,** Sweet potato leaves and stems can serve as a source of protein, as they generally contain 20-30% protein. The leaves and stems of Guazuma Urnifolia (West Indian Elm), Spondias Mombin (Hogplum), Caliantra, Sesbenia, Eritrema, Benzolive (including pods) and Leucena, are used to feed pigs in some areas. Local experience may indicate other edible leaves as a source of protein for pigs and humans.

In general, they should be used at a level no greater than 20% in the diet, with the exception of leucena. Leucena leaves and pods should not be fed to pregnant or lactating sows, nor to boars, to avoid problems with **mimosine toxicity**. It can cause abortion, sterility and hair loss. To non-lactating, non-pregnant sows, or young pigs, leucena can be used at a level no greater than 15% in the diet, to avoid **mimosine toxicity**. Leaves and stems should be chopped up so that the pig eats all the plant and not just the leaves.

Caution: Do not use tree leaves and stems from other trees or plants unless they are known to be safe. Many are poisonous for swine.

Amaranthus leaves can be used as a protein source for pigs, and the grain used as a feed source for people. The plant is first seeded, then replanted after 4 weeks. Then 3-4 weeks after the replanting, it is harvested. Amaranthus can still produce in dry areas. The main problem encountered, when raising amaranthus, is insect infestation. However, if properly sprayed with insecticide, it supplies a good feed source for people and pigs. The leaves can be used at a level up to 20% in the diet.

15. **Emergency Plant Protein Sources:** Very poor source of protein for pigs.

a. **Tung Nut Meal** — must have been detoxified for pig feed. It is not palatable unless fed in small amounts and mixed well. Use only in emergencies or for a short time.

b. **Kapok Oil Meal**: — This is another manufacturing by-product that can be used as a protein for pigs. It is much less desirable than others but it can be used.

c. **Palm Kernel Oil Meal Cake** — This is a manufacturing by-product, that is not a very appetizing, nor highly nutritious, protein source for pigs. However, it can be used in small amounts when no other protein is available.

B. Meat-Fish Sources of Protein:

1. Meat and bone sources of protein:

a. **Meat and Bone Scraps**

b. **Meat Meal and**

c. **Tankage**

All of these are meat processing by-products. These generally run 45-60% protein and are an excellent protein source for swine. If any of these products have not been cooked in processing, they should be cooked as for garbage. It supplies minerals.

2. **Blood Meal** — (80% protein) - This is another meat processing by-product that is a good protein source for swine. It is best used when other protein is fed and is of most value in larger growing animals.

3. **Fish Meal** — (50-70% protein), This is one of the best protein sources for swine and one of the most appetizing for swine. High cost limits its use in most areas. In some areas, it is available at a cost that makes its use in swine a possibility. It is especially good to get young growing pigs off to a good start, and to extend lesser quality protein. It does not give pork a fish taste.

Cooked Fish or Fish Scraps — Locally caught fish or fish scraps, if cooked, can be fed to swine as an excellent source of protein. In many areas, this could satisfy the protein needs of swine. Fish species, not appetizing to humans, can be used in swine. If not well cooked by boiling (and in the case of larger fish, also crushed or ground) bones may be a problem. In some areas, fish might be a source of disease and parasites if not well cooked. By-products of processing seafood other than fish can be used in swine rations. These would include scraps from fresh processing, as well as shrimp and crab meal, shark and tuna meal.

4. **Whey** — This is a by-Product of cheese making. Though low in protein, it is easily digested. It has about half the food value of skim and buttermilk, but should be used, if available at reasonable cost.

III Vitamins:

These are needed in small amounts, but they are necessary for good health, growth and reproduction. They are not used as a source of protein or energy, but they are essential for normal body functions. The vitamins most often deficient in swine rations are; Vitamin A, B Complex, and B12. Vitamin A is produced from carotene, which is found in green and yellow feeds, such as grasses and yellow corn or carrots. The B complex vitamins are found in green feeds and grain, and B12 in animal and fish products. In advanced swine production systems, swine are fed commercially produced vitamins. This is a necessity where swine are raised on concrete or in confinement buildings.

High cost, transportation problems, and heat inactivation necessitate that a practical and inexpensive solution to providing vitamins to swine be found. The answer to this, is the knowledge that the 14 vitamins swine required are generally available in feed, if some of the different categories are regularly fed. Some are produced by normal microorganisms in the intestine. This means grain or grain by-products, and plant and animal (or dairy) protein sources, need to be fed regularly. Many of these are available in forages being grazed or cut and brought to animals. Fruits and vegetables, especially those with yellow color, provide vitamins and should be fed as often as possible. Any source of fish or fish by-product, or animal protein, even if only occasionally, is a big help in providing vitamins.

Under most primitive production systems, **forage of good quality**, grazed or cut and fed to swine, or dried for later use, will adequately provide vitamins, if animals are fed a reasonably well-balanced diet. ***This is a simple and inexpensive way of providing vitamins, that are usually available.*** If good quality forage is not available, use any green grass or other palatable and not poisonous vegetation.

IV Minerals:

These are inorganic elements that are essential for many vital functions, and they are major components of the skeleton. Calcium, phosphorus, sodium and chlorine (salt) are the ones needed in larger amounts. Iron, zinc, iodine, selenium, copper and manganese are also needed, but in minute amounts.

Calcium and available phosphorus are too low in the usual carbohydrate-energy sources to satisfy the needs of swine, especially pregnant and nursing females.

Almost all of the usual foodstuffs are deficient in salt. Practically all feeds contain some minerals. The combination of feeds being fed determine the amount of extra minerals needed. Because the pasture and grasses harvested for forages have more mineral than seeds and

their by-products, **swine fed on pasture need less additional minerals.** They can obtain some of their mineral requirements directly by rooting in the soil, particularly iron and other minor elements.

We have to understand that the mineral content in grain and forage pasture depends to some extent on the **amount in the soil.** Where topsoil is limited due to very heavy rainfall, which depletes certain materials, we can expect that foodstuffs grown will contain lesser amounts of minerals. This, **almost always,** means that we have to provide **additional minerals,** since one or more of the above conditions prevails in most areas. Swine will not grow or reproduce well, without adequate minerals.

Where a complete mineral mix (calcium, phosphorus, salt and minor elements) is available, and at affordable cost, it should be fed, since only small amounts will be consumed daily. In other circumstances a practical solution can usually be found, if one has a basic understanding of the problem.

A good trace mineralized salt will supply salt and the minor elements—all that is needed except calcium and phosphorus.

Calcium is the principle component of Limestone (Lime) which is usually available and is the best source of calcium. It may also contain magnesium.

Steamed Bone Meal is a good source of calcium and phosphorus. **Defluorinated Rock Phosphate** is a good source of phosphorus and calcium. **Raw Rock Phosphate, with the Fluorine not removed, is poisonous to swine.** **Dicalcium Phosphate** contains both calcium and phosphorus, and works well for pigs. **Caution**—Do not use lime that has been heated or has had other ingredients added, as for cement or mortar mix. Protein supplied from animal sources also provides a source of calcium and phosphorus.

Possible Mineral Mixes that might be prepared locally.

Mix No. 1—Equal parts — ground limestone (or oyster shell)
— steamed bone meal
— trace mineralized salt (or iodized salt)

Mix No. 2—Equal parts — ground limestone (or oyster shell)
— dicalcium phosphate
— trace mineralized salt (or iodized salt)

Mix No. 3—Equal parts — ground limestone (or oyster shell)
— defluorinated rock phosphate
— trace mineralized salt (or iodized salt)

Mix No. 4—Equal parts — steamed bone meal or dicalcium phosphate
— trace mineralized salt

This mix is not as good as numbers 1-3 mixes, but can be used for pigs. Mix No. 5-Another mineral mix that can be used, though not as good, but simple and inexpensive is:

- 36 kg (80 pounds) of wood ashes and
- 9 kg (20 pounds) of trace mineralized salt

All of these mixtures should be daily fed free-choice to all ages, in boxes or feeders protected from rain, unless they are being fed as a complete ration containing minerals. If no other minerals are available, **wood ashes** can be fed. However, they are best used to extend other better quality minerals. It can be fed at one teaspoon (regular size 5 ml) daily per 45kg (100 pounds) body weight daily. It seems to have a small helpful effect in controlling intestinal worms. Bone meal or mixed minerals can be fed daily, at one teaspoon (5 ml) per 45 kg (100 pounds) body weight. In many areas there are cattle or poultry operations, that are using homemade or commercial mineral mixes, who will help other farmers. Although these are slightly different from the needs of pigs, they are much preferable to doing without minerals. They might help you obtain certain ingredients as trace mineralized or iodized salt.

Ground Oyster Shells (clam shells, coral, coquina or any seashell) (or mussel-fresh water shells) can be used when lime (limestone) is needed. Ground oyster shell is usually available wherever poultry are grown, but needs to be more finely ground for pigs.

Fish in the diet will provide iodine and other minerals, such as calcium and phosphorus, and selenium.

Note — Animal bones are often available. They can be **finely** ground or crushed by hand or a hammer mill. They should be **thoroughly cooked**, preferably in steam, **to kill germs**. Fresher bones are better for these purposes. They are good sources of calcium and phosphorus.

Note — Trace mineralized salt contains iodine and minor elements. It is less costly to transport than complete mineral mix with calcium and phosphorus. It can then be mixed with a calcium and phosphorus source. If trace mineralized salt is not available, use iodized salt rather than plain salt. **See later notes on Adding Iodine to Salt in the discussion on salt.**

Note — Commercial trace minerals without salt may be available.

They could be mixed with salt and the calcium and phosphorus sources, for a complete mineral by following the label directions. Since only very small amounts are used, transportation costs would be small.

A simple homemade mixer, adequate for mixing minerals, is described in the **discussion on salt**. There is a **drawing in the section on Buildings and Equipment**.

Calcium and Phosphorus Deficiencies are usually seen as swollen joints and arthritis in all ages, but is much more noticeable in young growing pigs a few weeks after weaning. Sows often show weakness and paralysis in rear legs and reproductive problems and poor milking is common.

Mineral needs are very great in animals being fed grain alone and no protein.

They are less critical in animals on good grazing and in animals fed on animal or fish protein.

Salt is the one mineral which swine *always* need. It may be fed loose or in blocks, or mixed into the ration. In most primitive systems it is fed loose, preferably in a free choice mineral mix. If not fed as part of a mineral mix, Trace mineralized salt or at least iodized salt should be used. It should be fed daily or as often as possible. Health problems may arise if hogs go very long without salt. Also, they may overeat salt when it becomes available with serious consequences if they have long been without it. Salt or mineral mixes should be kept covered to protect from rain. ***Water containing high levels of salt can be toxic to pigs.*** If salt is fed in a complete ration with a grain-carbohydrate source and protein, it should be used at 0.5% rate, equal to 224 g. (1/2 pound) in 45 kg (100 pounds) of feed or 4.5 kg (10 pounds) in 900 kg (one ton) of feed. ***If fed this way, do not give other salt.*** Animals should always have access to plenty of fresh water. ***Swine on complete feed with salt as an ingredient must have water constantly available or sickness will usually arise..***

Pigs lacking salt in their diet will lick boards, posts and other objects looking for salt. Their health generally is not good and growth rate suffers.

Other Mineral Deficiencies according to severity can cause a variety of health, reproductive and growth problems.

Iodine:

Since iodine is so important and iodized or Trace mineralized salt may be available, the following information is given.

Sources of iodine for mixing with salt

Potassium iodide	(readily available to livestock
Sodium iodide	But will leach or evaporate
Calcium iodate	from salt blocks)

Pentacalcium orthoperiodate (PCOP) is equal to above in availability, but will not be lost as rapidly from blocks. Used when exposed to rainfall.

EDDI (ethylenediamine dihydriodide)— Also useful for livestock. Less problem with moisture.

Potassium iodide is less desirable because of moisture problems, but it is often available, even in remote areas. Drug stores often stock it or can order it; you may also try chemical supply companies.

EDDI is an iodine containing preparation that is often fed to cattle. It might be available through feed dealers or possibly from cattlemen. It is not an expensive product. Because of the very small amount used, it can well be justified. An advantage is its moisture tolerance.

The following table provides a list of iodine containing preparations and amounts to be used in mixing with salt.

	<u>Amount of Product to Add to Salt to provide 0.007% Iodine</u>	
	% I	mg/kg gm/145 kg
Potassium iodide	76 92	4.2
Calcium iodide	65 108	4.9
Sodium iodide	85 82	3.7
EDDI	79 87	3.9
PCOP	26 270	12.3

Conversions:

- 1 ounce = 28.35 grams
- 1 gram = .03527 ounces
- 1 kg. = 2.2 lbs.
- 1 lb. = .454 kg.

In known iodine deficient areas, especially if goiter is seen, the amount of iodine may be doubled in salt or even tripled. The larger amount may be easier to mix.

Note 1: Iodine or trace minerals can be mixed with salt in small containers but the high dilution factor makes this very difficult. Take a clean 60 gal. (228 L) drum, and insert a steel rod through the center, insert the rod at an angle, and attach a handle. This suspended on a pole frame, makes an adequate mixer. It is especially good for mixing small amounts of feed and mineral mixes. **(See Drawing in section on Buildings and Equipment)**

Caution—Containers previously used for gasoline and oil are usually safe, if thoroughly cleaned with soap and water or steam. ***Never take a chance on a container that may have contained poisonous chemicals. They cannot be cleaned well enough to be safe.***

Note 2: If there is no other way to provide iodine, it can be furnished by dissolving 28 g. (one ounce) of potassium iodide in 3.8L(one gallon) of water. Feeding each sow one tablespoonful - large serving spoon (15 ml) of the solution on her feed once each week. ***This is used only as a last resort in known iodine deficient areas. Do not overdose!***

Iodine Deficiency in Pigs is seen as goiter (greatly swollen glands in the throat below the ears) of newborn and baby pigs with lack of hair. Animals do not grow and reproduce well.

Selenium is a mineral needed by animals, but in extremely minute amounts. It is deficient in most coastal flatlands, river valleys that flood, and most areas with high rainfall. Trace mineralized salt often contains selenium, and would be preferred if available.

V. Water:

Water **is the most important nutrient** required by swine, yet it is one of the most neglected aspects of swine production.

Since water is so important, the following table is given for information. For their size, swine require a surprisingly large amount of water.

<u>Weight of Hog</u>	<u>Amount of Drinkin Water/Day</u>
22.5 kg - 50 pounds	Up to 3.8 L - One gallon
45 kg - 100 pounds	5.7 L - 1.5 gallon
67.5 kg - 150 pounds	7.6 L - 2.0 gallon
90 kg - 200 pounds	9.5 L - 2.5 gallon
112.5 kg - 250 pounds	11.4 L - 3.0 gallon
Pregnant Sow	15.2 L - 4.0 gallon
Lactating Sow-with nursing pigs (milk is around 80% water)	22.8 L - 6.0 gallon
Weanling Pig	1.9 L - 0.5 gallon

In extremely hot weather, they may need even more water. If possible swine should have water constantly available or several times daily. Swine given fresh water, instead of ground (surface), pond or stream water, will have much less parasite and disease problems.

However, regardless of the source, it must **be frequently** available. Homemade inexpensive troughs, and other suitable containers for water, are shown in the section on Buildings and Equipment. Surprisingly, pigs prefer clean fresh water to dirty surface water.

V1. Methods of Feeding Pigs:

Pigs may be fed in a number of ways. The farmer may combine methods to fit his situation. For example, he might hand feed limited amounts of protein and grain, and graze on good quality forage.

A. **Self-Feeding** — This requires a feeder in which feed is placed and pigs are allowed to eat at will. This is usually done where larger groups of growing animals are being fed. Sows should **not** be self-fed; they will become too fat and have trouble with farrowing and milking. Self-feeding is not practical in most primitive situations, or where only a few animals are being fed. Its advantage is in saving labor. A **drawing** of a self-feeder is shown in the section on Buildings and Equipment.

B. **Hand-Feeding**—This is done with small groups where one wants to limit feed to sows. Small amounts are fed one or more times daily, in troughs or other containers. Animals are fed no more than the amount they will consume at the time. There is much less waste and a healthier situation when feed is placed in troughs or other containers, rather than, on the ground. Hand-feeding takes more time and labor than self-feeding, but no expensive equipment. This is the most common method of feeding in small operations and under primitive conditions.

C. **Gleaning** is a good and simple way to fatten animals. **After harvest**, pigs are turned out to clean up waste grain, rice, peas, beans, and other crops. The stubble or other remains alone may be adequate, but extra protein is usually needed. Gleaning is good for pregnant sows. Animals under 3 months of age will not do well on stubble. Nursing sows will need additional grain and protein, in most situations. This feeding method saves time and should be used in almost all circumstances, following harvest.

It is a method where pigs save food otherwise lost.

D. **Hogging Down**—This is similar to gleaning. It is a way of letting pigs harvest their own feed. It saves labor, but is not as efficient as other methods because some feed is lost. This method may be used for almost any crop except soybeans. Some additional protein should be fed, unless animals are on beans or peas, which contains adequate protein. Sows and fattening animals, over 3 months of age, do well. Younger animals do not do as well. There is less waste of feed if a small area is used until all the feed is gone, and then another area is used. Smaller animals often cannot reach the feed. One or more older pigs should be in the group to help break plants down. **Water** should always be available, closeby, to animals gleaning or hogging-down crops.

Labor saving is the primary advantage in hogging-down crops. The loss of feed is too great to justify its use, in most cases.

E. **Pasturing-Grazing**.—As already mentioned, this is good for all ages, especially pregnant and nursing sows and young pigs. If forage is plentiful, this is best, but it can be wasteful. Animals may damage much of the food. In many cases, it is best to cut it and bring to the animals. Grazing animals get sunlight and exercise, plus moderate amounts of carbohydrate and protein, as well as vitamins and minerals.

Pregnant animals, especially nursing sows, need additional grain and protein.

F. **Hay-Dried Forage**—This is a method whereby excess forage is preserved by drying for use at a later time. This evens out the food supply between better growing seasons and poor growing seasons. It saves on the cost of purchased ingredients. While not efficient users of dried forage, as are ruminants, older pigs can use it to greatly extend grain-carbohydrate and protein source foods. It contains minerals and vitamins. The forage should be cut for hay near the time of maxi-

mum growth, but while still tender and green. It should be dried as rapidly as possible. This often means that it has to be protected from daily rains, and then placed out in the sunny part of the day, or dried under sheds.

Hay-dried forage should be ground or crushed for better digestion in pigs.

G. **Creep Feeding**—This is a method that provides nursing pigs with feed that is not accessible to the sow. It is a method that introduces nursing baby pigs to solid food and greatly reduces the shock of weaning. The sow's milk production begins to decrease when the pigs are around 3 weeks of age. Creep-feeding helps offset the lessening milk flow and helps pigs grow faster. A small shallow trough or other container is placed in a small enclosure with an opening large enough for only baby pigs to enter. **See drawing in section on Building and Equipment.**

Finely ground feed, mixed with milk, should be fed to baby pigs in the creep area, starting at 2-3 weeks of age. When pigs are eating well, milk is not necessary, but it is still a great help if available. **Bread scraps can be fed instead of ground food.** Do not let milk spoil; it can make pigs sick. Clean troughs often, if milk is fed. There is more information in the **section on Baby Pig Management**, and sample rations 1-3 at the end of the section on Nutrition.

Food Preparation for Pigs:

1. **Grinding (or crushing)** small grains, such as wheat, oats, barley, and sorghums, milo and millet is almost a necessity for efficiently growing swine. Baby pigs require ground grain. Corn can be fed whole in older animals, **but it has to be ground for baby pigs.** Other small grains can be fed whole, but not as efficiently. Hammer mills are most often used for grinding, but may not be available in many areas. Small portable hand grinders, used for making corn meal and flour, are available in many areas. They are slow but satisfactory. In very primitive situations, mortar and pestle can be used for a few sows and baby pigs.

2. **Soaking** is a poor alternative to grinding small grains, to improve digestibility. It is not as good as grinding. Grain is placed in clean water in a container and fed after soaking 24 hours. Feed soaked over one day may ferment and cause problems.

3. **Cooking Grain or Forage**—This does not improve digestibility, and is not recommended. However, rice products need to be cooked.

4. **Cooking Potatoes and Bean and Peas**—This does increase food value and is recommended. Potatoes may be cooked with dry heat, or steamed, or boiled. They should then be cut into small pieces or ground into meal. **Beans** should be steamed or boiled to eliminate the bitter taste. They are more digestible if ground or crushed before feeding. **Soybeans have to be well cooked.**

5. **Grinding or Chopping Hay or Dried Vegetation** allows pigs to make better use of it and should be done.

6. **Chop fruit** and vegetables into small pieces to avoid choking and increase feed consumption.

Feeding a Balanced Ration:

Pigs require a balanced ration for good health, growth and reproduction. Daily, or as often as possible, the following categories of foodstuff should be fed.

1. A grain-carbohydrate source or grain substitute.
2. A protein source, plant and/or animal.
3. Mineral and salt source-preferable free-choice.
4. Vitamin source-usually green forage.
5. Adequate water-at all times.

A highly detailed discussion of balanced rations for pigs is beyond the scope of this booklet. However, the following guidelines should be a big help.

1. Generally the diet of pigs should contain around 75-80% grain-carbohydrate (or grain substitute) sources and 20-25% from protein sources, with minerals and salt fed free choice or mixed in feed. At least some green forage being grazed or brought to animals, or fed as dried hay, is desirable.

2. In most primitive situations, grazing will of necessity replace much of the grain-carbohydrate and protein source feeds. Growth and reproduction will suffer as higher amounts are fed.

3. Grain-substitute feeds will, of necessity, replace much of the grain in the ration. Again, this is done at the sacrifice of fast growth and reproduction, and is not as efficient.

4. Better quality feed (more grain and protein) should be fed to nursing sows and baby pigs.

5. Poorer quality food can be fed with less problems to larger growing animals.

6. Protein source foods should not make up over 1/3 of the diet.

7. Commonly used grains-corn, oats, wheat, barley, rye and sorghums contain around 7-8% protein. However, this is not enough for pigs to do well without at least some additional protein.

Grain, with no additional protein can be fed to larger growing animals, with slowed growth the only consequence. However, vitamins and minerals should be provided. Grain with good quality grazing for large growing animals is often satisfactory, except for a slightly slowed growth rate. Grain alone is not adequate for nursing sows. Grain with good quality grazing is better, but additional protein is needed. Vitamins and minerals should be fed.

8. Fruit and vegetables should not make up over 1/3 to 1/2 of the total diet. However, conditions often dictate greater use of these. The higher amounts would be best used in larger growing animals, rather than in sows and baby pigs.

See other notes on feeding in the **Section on Management**.

Caution: Avoid **sudden changes in type** (source) and **amount** of each ingredient in the ration. Serious digestive upsets and other health problems may occur. This is especially true of high percentage protein source foods.

Pregnant and nursing sows and baby pigs are especially sensitive to sudden diet changes.

To prevent problems, gradually add newer ingredients, or increase regular ingredients by small amounts over several days.

Feeding Pregnant Sows

Pregnant sows should gain 18-34 kg (40-75 pounds) between breeding and farrowing. This will vary according to her size, and condition (amount of body fat) at breeding. If she is extremely fat or too thin at farrowing time, she will often have problems delivering the baby pigs.

She will not give enough milk. While good grazing will supply part of her carbohydrate and protein needs, she still needs at least .112-.224 kg (1/4-1/2 pound) of protein source food per day, and some grain or grain substitute, in order to produce normal pigs and milk well.

Feeding the Nursing Sow:

Sows should gradually be fed increasing amounts of food from the day after farrowing until on full-feed, at around 10-14 days after farrowing. If possible, an approximate 80% grain source-20% protein source ration, or close to this as possible, should be fed, this should start at 450-900 g. (1-2 pounds) per day and increase by 450 g. (one pound) per day until on full feed, (all that she will eat daily). Sows fed too much the first few days after farrowing may produce too much milk and cause digestive upsets in the baby pigs. Good quality grazing is a big help to the nursing sow, and can replace part of the grain-protein source foods. It is advised for most primitive production systems. However, in order to milk well, some added grain and **protein source foods are needed**. Even in small amounts, they are a big help. Never let the nursing sow and baby pigs use old contaminated lots and pastures. This helps prevent worm problems.

Fruits and vegetables, with the exception of a few, such as bananas, pumpkin, coconut and breadfruit, are too low in food value to feed to nursing sows, except in small amounts and in emergencies. A constant supply of fresh water is necessary, if sows are to milk well. Remember the nursing sow is in a very nutritionally stressful period. You should use good

judgment! About a week before weaning, gradually reduce the sow's ration to decrease milk flow. This will help dry up her milk and lessen chances of udder (breast) injury, and mastitis (udder infection).

Feeding Baby Pigs:

When pigs are 2-3 weeks old they will eat a little grain. They will accept it better if it is ground and mixed with milk. Bread scraps in milk work well. The food should be placed in a **creep** area, as previously described. As pigs become older and nearer weaning, they should receive small amounts of the protein. Milk is not necessary in the feed, after pigs are eating well but if it is plentiful it should be continued. Give pigs only what they will consume daily, the food will soon spoil.

Creep feeding is not inconsistent in primitive pig production systems. In fact, it is one of the **most recommended** management practices in raising healthy pigs. The creep feeding area should be located convenient to the baby pigs, preferably near their shelter and close to a source of water. **See drawings in section on Buildings and Equipment.**

Feeding the Grower-Finishing Pig:

This is the age between weaning and market, or home butchering. It deserves special consideration, because a high percentage of feed is used during this time. It is a time in the pig's life when we have many options to consider in feeding these animals. As previously mentioned in feeding pigs of other ages, a ration based on 75-80% grain-carbohydrate source and 20-25% protein source, with salt and minerals and green forage (or dried) is the preferred ration. Pigs of this age have less critical nutritional needs than pregnant or nursing sows and baby pigs. Although growth will be slowed and health problems may occur, this is the age that is most often fed on the grain-carbohydrate substitutes and garbage.

Surplus or inexpensive fruits and vegetables can be fed in larger amounts to this age pig.

In almost all primitive situations, this age pig should be grazed on some form of green forage, or have it brought to them. Good quality forage can greatly offset the deficiencies that would otherwise occur, if a balanced diet were not being fed.

Sample Rations:

Under primitive production systems, there will be very few times when complete rations, using ground ingredients, will be fed. However, there

might be circumstances where this information would be useful. A few sample rations follow. There are many others that could be used, based on other ingredients mentioned previously.

1. **Sample Ration No. 1** — Creep feed for baby pigs

- 33.75 kg — 75 pounds corn -finely ground
- 11.25 kg — 25 pounds protein meal — preferably part or all from animal or fish
- .225 kg — 1/2 pound trace mineral salt
- .225 kg — 1/2 pound ground limestone
- .225 kg — 1/2 pound steamed bone meal or dicalcium phosphate or defluorinated rock phosphate

This is a very simple but adequate ration.

2. **Sample Ration No. 2** — Creep feed for baby pigs

- 26 kg — 58 pounds corn, finely ground
- 10 kg — 22 pounds soybean meal or other oil seed meal
- 2.25 kg — 5 pounds tuna or other fish meal
- 1.38 kg — 3 pounds wheat middlings
- 4.5 kg — 10 pounds molasses or sugar
- .225 kg — 1/2 pound trace mineral salt
- .225 kg — 1/2 pound ground limestone
- .225 kg — 1/2 pound steamed bone meal or dicalcium phosphate or defluorinated rock phosphate

3. **Sample Ration No. 3** — Creep feed for baby pigs

- 27 kg — 60 pounds corn, finely ground
- 9 kg — 20 pounds soybean meal
- 2.25 kg — 5 pounds dried skim milk, milk replacer or mix other ingredients in milk
- 6.75 kg — 15 pounds sugar or molasses
- .225 kg — 1/2 pound trace mineralized salt
- .225 kg — 1/2 pound ground limestone or finely crushed oyster shell
- .225 kg — 1/2 pound steamed bone meal or difluorinated rock phosphate

In all creep rations, wheat or oats may be substituted for corn, with little difference. Other grains, such as barley, rye, and sorghum, do not work as well in baby pig rations, but may be used if available and are finely ground.

4. **Sample Ration No. 4** — Pregnancy ration—hand fed

- 35.5 kg — 79 pounds grain
- 8 kg — 18 pounds soybean oil meal
- .45 kg — 1 pound ground limestone or finely ground oyster shell

- .45 kg — 1 pound steamed bone meal or Defluorinated Rock Phosphate or DiCalcium Phosphate
- .225 kg — 1/2 pound Trace mineral salt
- 5. **Sample Ration No. 5** — Pregnancy Ration—Hand Fed
 - 37 kg — 82 pounds grain
 - 3.6 kg — 8 pounds soybean oil meal
 - 3.15 kg — 7 pounds fish meal
 - Minerals and salt as in Ration No. 4
- 6. **Sample Ration No. 6** — Pregnancy Ration—Hand Fed
 - 10.8 kg — 24 pounds grain
 - 9 kg — 20 pounds molasses
 - 11.25 kg — 25 pounds pineapple bran
 - 2.25 kg — pounds fat
 - 7.65 kg — 17 pounds soybean meal
 - 3.15 kg — 7 pounds fish meal
 - .225 kg — 1/2 pound steamed bone meal
 - .225 kg — 1/2 pound Trace mineralized salt
- 7. **Sample Ration No. 7** — Nursing Sow Ration
 - 35.1 kg — 78 pounds grain
 - 8.5 kg — 19 pounds soybean meal
 - .225 kg — 1/2 pound Trace mineral salt
 - .45 kg — 1 pound steamed bone meal or Defluorinated Rock Phosphate or DiCalcium Phosphate
 - .45 kg — 1 pound ground limestone
- 8. **Sample Ration No. 8** — Nursing Sow Ration
 - 36.9 kg — 82 pounds grain
 - 4.95 kg — 11 pounds soybean meal
 - 2.25 kg — 5 pounds fish meal
 - .225 kg — 1/2 pound Trace mineral salt
 - .225 kg — 1/2 pound steamed bone meal or Defluorinated Rock Phosphate or Di Calcium Phosphate
 - .225 kg — 1/2 pound ground limestone or finely ground oyster shell
- 9. **Sample Ration No. 9** — Nursing Sow Ration
 - 25.6 kg — 57 pounds grain
 - 9 kg — 20 pounds molasses
 - 6.75 kg — 15 pounds soybean meal
 - 1.8 kg — 4 pounds fish meal
 - 0.9 kg — 2 pounds meat and bone meal
 - .225 kg — 1/2 pound ground limestone or finely ground oyster shell
- 10. **Sample Ration No. 10** — Growing Ration—Low Protein
 - 39.1 kg — 87 pounds grain
 - 4.5 kg — 10 pounds soybean meal
 - .225 kg — 1/2 pound Trace mineral salt

- .45 kg — 1 pound Steamed bone meal or dicalcium phosphate or defluorinated rock phosphate
- .34 kg — 3/4 pound ground limestone or finely ground oyster shells

This is an example of a simple grain-soybean meal ration.

11. **Sample Ration No. 11** — Growing ration-medium protein
60 pounds grain .

- 27 kg — 12 pounds soybean meal
- 5.4 kg — 4 pounds fish meal
- 1.8 kg — 2 pounds meat and bone meal
- 0.9 kg — 20 pounds molasses
- 9 kg — 1/2 pound trace mineral salt
- .225 kg — 1/4 pound ground limestone or finely ground oyster shell
- .113 kg — 1/4 pound steamed bone meal, dicalcium phosphate or difluorinated rock phosphate

This ration is more complex with several protein sources.

12. **Sample Ration No. 12** — Growing finishing ration-high protein

- 27.5 kg — 61 pounds grain
- 7.7 kg — 17 pounds soybean meal
- 1.6 kg — 3-1/2 pounds fish or tuna meal
- 1.1 kg — 2-1/2 pounds meat-bone meal
- 6.8 kg — 15 pounds molasses
- .225 kg — 1/2 pound trace mineral or iodized salt

13. **Sample Ration No. 13** - Growing finishing ration

- 13.5 kg — 30 pounds soybean meal
- 2.25 kg — 5 pounds tuna or fish meal
- 21.8 kg — 48 pounds molasses
- 4.5 kg — 10 pounds bagasse pulp
- 2.25 kg — 5 pounds vegetable oil or other edible fat
- .225 kg — 1/2 pound Trace mineral or iodized salt
- .225 kg — 1/2 pound steamed bone meal or defluorinated rock phosphate or dicalcium phosphate

Special Notes:

1. Where minerals are being fed free choice, you may be able to eliminate them from the above rations.

2. These rations are based on the assumption that animals are grazing or being hand fed green forage or good quality hay.

3. Generally, animal-fish and plant source protein may be interchanged in rations, with little or no adjustments. Animals grow and reproduce better and healthier when some of each is fed. When animal or fish protein is substituted for plant source protein, less is needed, around 10-20% less.

4. Cooked soybeans (preferably with dry-heat), that are crushed or ground, may be substituted for soybean meal, in these sample formulas. They should be used at a slightly higher level, around 20% more than soybean meal. The additional fat, in the cooked beans, helps nursing sows produce more milk. It would help balance out a ration that was deficient in grain-carbohydrate. Since soybeans can be grown in many areas and require very little commercial fertilizer, growing them and home-cooking for swine feed, would seem to be a good idea.

Caution: Since cooked soybeans contain more fat, the rations made from them spoil more quickly. The ration should be made often and in small amounts.

There are many other potential food sources available for pigs. A little imagination and a few dollars spent on a small scale experiment could possibly mean a breakthrough of great importance in your area. The author would appreciate hearing about other foods used for pigs.

Section IV

Management Practices

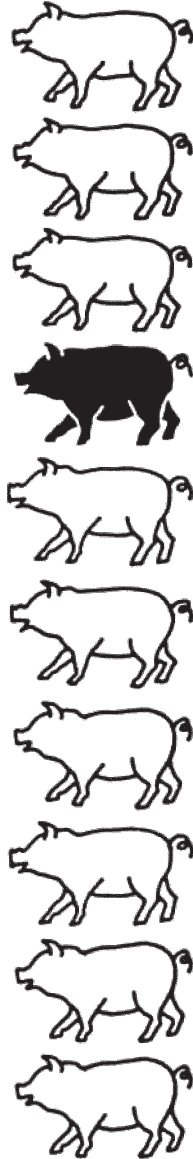

Reproduction

Covers Management Practices from Breeding
through Farrowing

A. **Selection of Young Females (Gilts) for Breeding Animals.** Look for the following:

1. Select females from **best milking mothers** (dams).
2. Select females from **largest litters**.
3. Select **larger, faster growing** females of litter.
4. Select **females, no obvious defects** such as hernias, lameness and other health problems.
5. Females with **at least 10 well developed**, well spaced teats (preferably 12 teats). None of the teats should be "blind" (non-functional teats) which do not protrude, as do normal teats.
6. Be of **Desired Body Type**.
 - a. Short blocky fat type animals, if cooking fat is in demand.
 - b. Long lean, muscular type animals, if lean meat is much in demand.
 - c. In most situations, the preferred body type is a compromise between the first two types.
7. **Purchase** from herds with as few health and disease problems as possible. **Purchase** virgin females that have never mated with a boar. This greatly lessens the chances of her introducing one of the diseases that cause reproductive problems.

B. **Selection of Males (Boars) for Breeding Animals**

1. He should have the rugged masculine appearance of a male.
2. Free from hernias, lameness and other health defects.
3. Two large, well-formed testicles.
4. From a large litter.
5. Fastest growing males of the litter.
6. Not related to your females—preferably from a different herd than your females.
7. From herds that are as disease free as possible.
8. Body type as referred to in female selection.
9. Preferably of another breed to get advantages of cross-breeding.

If no good quality boars are available in the immediate area, it may be necessary to look elsewhere. In most countries, there are herds with high quality breeding animals. The high cost of these animals, and transportation problems, may make it impossible for most small farm operations to obtain them. There are foundations and organizations that can help, such as Heifer Project in Little Rock, Arkansas, and many church groups as well. The male pigs from one high quality boar can then go into other herds and improve them.

One good male can help genetically, as much as many females, at much less cost.

Always purchase **virgin boars**. This greatly lessens the chances of introducing disease. This is especially true if you are purchasing higher priced animals.

Blood Tests for Purchased Breeding Stock—Purchase of virgin females and males, from herds with no known disease problems, is always a good idea. An even better safeguard, would be blood tests for diseases, such as brucellosis. However, this is only possible where there is a veterinarian in the area.

C. **Physiology of Swine Reproduction—An Understanding**

Swine are not seasonal breeders. This means that their reproductive cycles are not directly affected by seasons. However, in areas with more extremes of winter and summer, they often tend to farrow more in spring and fall with milder weather. Generally, the gilt from her first heat (estrus) or the sow after weaning her pigs, will continue to cycle regularly until she becomes pregnant, or is nursing pigs, or develops a health problem.

1. **Heat (Estrus)** The 2 or 3 day period when the female will accept the male in the mating act. **It is seen** as a swelling of the vulva (external female genitalia) and a sudden show of interest by the male. It is the only time the female will accept the male.

2. **Heat Cycle (Estrus Cycle)** The interval between heat (estrus) periods. It averages 19-21 days, but may vary by another day or two.

3. **Ovulation**—This is the release of the ova (egg) by the **ovary** (female sex glands) so that it can be fertilized by the male's sperm. Ovulation generally occurs the second day of heat. That day and the next day are when mating (breeding) should take place for best conception (fertilization of ova by sperm).

4. **Conception**—This is the fertilization of ova by sperm following the mating act.

5. **Female Puberty**—This is the time of the first heat period and first desire to mate with the male. It varies by breed, size, nutritional conditions, other health factors and by climate. It may be as early as 6 or 7 months, or as much as a year of age.

6. **Male Puberty**—This is the time of their first desire and ability to mate with the female. It is generally a month or so earlier than in the female but varies because of the same factors.

Breeding (Mating) Methods—There are two methods of breeding (mating); hand breeding and pen breeding.

In **Hand-breeding** the male is kept separate from females. When the female is noticed in heat she is brought to the male for breeding. The advantages of this are that the male may serve more females and is not left with the pregnant females. (There is a chance that the male

may injure the females if left with them). The disadvantage is that someone has to closely observe the females for heat daily, and extra labor is required in moving the female to be bred. It requires someone experienced in observing heat.

In **Pen-Breeding**—the male stays with the females until you are certain that females have conceived. The advantages are that the male will find the female in heat and no labor is required in moving the female. The disadvantages are that the male may injure pregnant females and that he cannot serve as many females. This, ***because of its simplicity, is the method usually used in primitive systems.*** If a herd is successful and gets larger than a few females and one boar, then hand-breeding is often used.

Age to first breed females—As previously mentioned in notes on puberty, the age of the first heat varies because of many factors. It is rare to breed gilts under 8 months of age. Some gilts do come in heat earlier but, unless they are fully grown, should not be bred until they are 8 months old. In most primitive situations, gilts grow slowly and reach puberty late and are bred later.

Gilts bred too small, will not grow to normal size and often have trouble at farrowing time.

Age to first breed males—Young boars are usually not bred before 8-10 months of age. Those that reach puberty earlier may be bred occasionally, but litter size is often small and conception is poor.

Time of Year to Breed Females—Left on their own, swine will breed year around. Where there are distinct seasons they tend to farrow more in the spring and fall. Since baby pig survival is best in least severe weather, it is a good idea to breed sows to farrow during these times. In areas with heavy rainfall at one season, it is a good idea to avoid farrowing during that time. In areas with little seasonal changes the time of year to farrow would not be of importance, unless there were some other factors such as seasonal market demand or transportation problems. Availability of adequate food during gestation and lactation could be a factor.

State of Heat to Breed Females—The best time to breed the females is on the second day of heat. If she is still in heat on the third day, breed her again. Conception is much better with two matings. Of course, where the boar is running with the females he usually breeds them several times.

Breeding Sows After Weaning—Sows generally come into heat 3-7 days after pigs are weaned and are mated at that time. If they are too thin, they should not be bred on the first heat. They need time to put on some flesh before being bred. Occasionally, a sow will come into heat when pigs are 2-3 weeks old and still nursing. They should not be bred at this heat.

Length of Pregnancy (Gestation in Swine)—The length of pregnancy in swine averages 114 days, with up to 3-4 days variation earlier or later. An easy way to remember it, is the often heard “three months 3 weeks and 3 days”. For example, a sow bred on January 1 will farrow around April 24. It is important to keep good breeding records in order to give the sow some special care the week prior to farrowing.

Gestation Table
Dates of Breeding and Farrowing for Sows
(Based on 114-day gestation period)

Bred	Due	Bred	Due	Bred	Due
Jan. 1	Apr. 25	May 1	Aug. 23	Sept. 1	Dec. 24
Jan. 5	Apr. 29	May 5	Aug. 27	Sept. 5	Dec. 28
Jan. 10	May 4	May 10	Sept. 1	Sept. 10	Jan 2
Jan. 15	May 9	May 15	Sept. 6	Sept. 15	Jan 7
Jan. 20	May 14	May 20	Sept. 11	Sept. 20	Jan. 12
Jan. 25	May 19	May 25	Sept. 16	Sept. 20	Jan. 17
Jan. 30	May 24	May 30	Sept. 21	Sept. 30	Jan 22
Feb. 1	May 26	June 1	Sept. 23	Oct. 1	Jan. 23
Feb. 5	May 30	June 5	Sept. 27	Oct. 5	Jan. 27
Feb. 10	June 4	June 10	Oct. 2	Oct. 10	Feb. 1
Feb. 15	June 9	June 15	Oct. 7	Oct. 15	Feb. 6
Feb. 20	June 14	June 20	Oct. 12	Oct. 20	Feb. 11
Feb. 25	June 19	June 25	Oct. 17	Oct. 25	Feb. 16
Feb. 28	June 22	June 30	Oct. 22	Oct. 30	Feb. 21
Mar. 1	June 23	July 1	Oct. 23	Nov. 1	Feb. 23
Mar. 5	June 27	July 5	Oct. 27	Nov. 5	Feb. 27
Mar. 10	July 2	July 10	Nov. 1	Nov. 10	Mar. 4
Mar. 15	July 7	July 15	Nov. 6	Nov. 15	Mar. 9
Mar. 20	July 12	July 20	Nov. 11	Nov. 20	Mar. 14
Mar. 25	July 17	July 25	Nov. 16	Nov. 25	Mar. 19
Mar. 30	July 22	July 30	Nov. 21	Nov. 30	Mar. 24
Apr. 1	July 24	Aug. 1	Nov. 23	Dec. 1	Mar. 25
Apr. 5	July 28	Aug. 5	Nov. 27	Dec. 5	Mar. 29
Apr. 10	Aug. 2	Aug. 10	Dec. 2	Dec. 10	Apr. 3
Apr. 15	Aug. 7	Aug. 15	Dec. 7	Dec. 15	Apr. 8
Apr. 20	Aug. 12	Aug. 20	Dec. 12	Dec. 20	Apr. 13
Apr. 25	Aug. 17	Aug. 25	Dec. 17	Dec. 25	Apr. 18
Apr. 30	Aug. 22	Aug. 30	Dec. 22	Dec. 30	Apr. 23

From Oklahoma State University Extension Fact Sheet No. 3653.

Managing Pregnant Females—Basically, it is important remember that the pregnant animal is an expectant mother. The life of the pig begins at conception and the ration fed the pregnant sow is extremely important, (refer to previous notes in nutrition section of feeding of pregnant animal).

In order to help prevent farrowing difficulties and milking problems, the pregnant female needs to be kept in good condition (fleshing). She should neither be too thin, nor too fat. A good rule "if too fat you cannot feel the spine over the back; if too thin, you can see the spine".

After she is obviously pregnant, not coming into heat on the 19-21 day cycle and showing sign of udder enlargement, she should not be allowed to run with the boar.

The unborn pig, especially early in pregnancy, can be affected if the sow becomes overheated. For this reason she should be given protection from extreme heat and not overly exerted, as in moving her or excited by other animals.

If at all possible, the pregnant female should be allowed to graze on the best forage available. The nutritional value of the green forage and the exercise help her to develop healthy pigs.

Care of the Male—The male should be fed very much like the pregnant female. He should stay in a medium state of flesh; not too fat, nor too thin. Boars too thin will not perform well and those too fat tend to be lazy and poor breeders. The boars should be fed very much the same as pregnant females. However, if he is breeding sows often he may lose weight. If this happens, he should be fed more to keep him in the medium state of fleshing.

When there are no females to breed, he should be kept separate from the other pigs. He needs at least a quarter of an acre so he can get exercise, with adequate protection from extreme weather. He should be able to graze or green food should be brought to him, to supplement his other food.

His pen or pasture should be moved occasionally to prevent health problems.

Boar Use—The boar can breed more females, in a given period, as he grows older. Males under 1 to 1½ years of age should not be used to breed more than 2 or 3 females per week. As they become older they can be used to breed more females, up to as many as six per week, if they do not come into heat at the same time. In most primitive situations, where there are only a few sows, it would be rare for him to be bred too often. One mature boar should be enough for 10-12 sows.

When weaning pigs from sows do not wean several sows at one time. This is especially important if there is only one boar. They will come in heat about the same time and the boar may be overworked. Small litters may be the result.

Protection from heat is very important. Extreme heat has the effect of killing sperm in males for around 30 days. **Females will not conceive.** Avoid undue exertion in moving and handling and provide protection from extreme heat. A boar that has been sick with a high fever usually cannot effectively breed for 30 days. The following practices will improve conception:

1. Hand breed before 8:00 a.m. or after 6:00 p.m.
2. Pasture breed at night and return the boar to his own pen in the day.

Tusk Removal in Boars—Most boars develop long protruding teeth at the corner of the mouth, called tusks. They become larger as the boar grows older. They can be very dangerous to the farmer and his family and to other pigs. Usually by the time the boar is one and a half years of age, they have to be removed. To remove the tusks, the boar is restrained by way of a rope tied around the upper jaws behind the tusks and the rope tied to a post or tree. Large nippers such as bolt cutters, or a saw, is used to remove the part of the tusk above the gum line. Try not to damage the gum. This may have to be repeated later.

Sharing Boars by Different Farmers—This is a situation of too few sows on one farm to justify a boar. Due to the cost of the boar this may mean that two or more farmers must use the same male. There is a considerable risk because there are diseases that he can spread when sharing animals. Where the farms are near each other, or where animals often intermingle, the diseases may have already spread.

There is one situation where the boar should not breed females from other farms. This is when a superior male is brought in to improve the pigs in a community. The health of the superior boar should be protected by keeping him on one farm, and using his male offspring to spread his genes to other farms. He should also be kept away from pigs running loose.

Health Tests for Breeding Animals—There are several breeding diseases that can be very serious. Boars and sows should be tested for brucellosis, if there is anyone available to do it. Blood samples are tested at laboratories and some can be done on the farm. If possible, animals should be tested prior to purchase. (See Other Information in Health Section).

Preparation for Farrowing (Delivery of Baby Pigs)—Decide how you want to handle sows at farrowing.

Farrowing Methods:

1. **Pasture Farrowing**—sows and baby pigs are left on their own.

Advantages—no facilities required.

—no labor involved.

—No experience needed by owner.

Disadvantage—can't assist with farrowing problems.

—can't help newborn pigs.

—more pig deaths result from bad weather and wild animals

2. **Pen Farrowing**—sows moved to small pen with a shed for days before farrowing.

- Advantages**—can help sows and baby pigs if they need assistance.
- some weather protection.
 - temporary facilities can be moved, (and should be moved) to lessen diseases and parasites.
 - more pigs saved.

Disadvantage—facilities required.
need slightly more experienced help.

This would be the system most practical for primitive locations.

3. **Farrowing in Buildings**—with floors.
- sow closely confined and easy to help
 - pigs can be better protected from weather.

Disadvantages—cost of facilities

- need experienced help
- sanitation problems often lead to sickness.
- have to prevent baby pig anemia (see Note) on Baby Pigs later.

Signs of Approaching Farrowing Time

2-3 weeks before farrowing—udders (breasts) becoming noticeably enlarged.

5-7 days before farrowing—vulva (external genitalia) noticeably enlarged.

24-48 hours before farrowing—milk appears in teats.

12-24 hours before farrowing—sow becomes very nervous, restless, and carries dried vegetation to make a bed.

Assisting with Farrowing—Old sows seldom need help with farrowing. Gilts often need help with their first litter. If a pig lodges in the pelvis bones (birth canal) it soon dies, usually in 30 minutes, unless delivered. If it remains there more than an hour or two, the next pig also dies. If a pig lodges for 12-24 hours the other remaining pigs die, and often the female dies.

A clean, well greased hand and arm can often reach the lodged pig. Grasp the feet, if possible, and remove the pig with the least possible force. If the feet cannot be grasped, use the head. Often the first pig is the problem. Others follow normally when it is removed.

A woman, because of her small hands, can often assist far better than a man.

Caution: Always wash and disinfect hands after assisting in farrowing or handling newborn pigs. ***Never assist in farrowing, if there are cuts or bad scratches on your hands. Rubber gloves are much better to reduce risk of human infections that can occur.***

Fetal Membrane (Afterbirth)—contrary to the opinion of the uninformed, should not be fed to sows; rather, they should be burned or buried, soon after all pigs are delivered.

Feeding the the Lactating Sow (Newborn Pigs)—Refer to notes on Nutrition Section.

Helping the Newborn Pig—The degree of involvement with helping the newborn pig will vary with the skill of the owner and the facilities. Newborn pig survival is much greater when as many of these as possible are done.

On Arrival—remove from membranes.

- wipe mucus from mouth and nose with a clean cloth.
- clip the navel cord (umbilicus) 1-2 inches long with scissors and spray or dip in iodine. Wait at least 20 minutes but not over 2-3 hours to do this. If the cut cord bleeds excessively, tie it with cotton string or fish line.
- if weather is cold, dry pigs off with a clean cloth soon after delivery. You may put them in a box or basket lined with straw until all pigs are delivered, but not longer than 2-3 hours.
- they must nurse as soon as possible to get colostrum (milk in udders at birth that gives protection from infection.)

▶
*Cut needle teeth.
Pigs are born with
eight needle teeth,
four on each jaw.
They should be
cut to prevent in-
jury to the sow's
udder or to litter's
mates.*

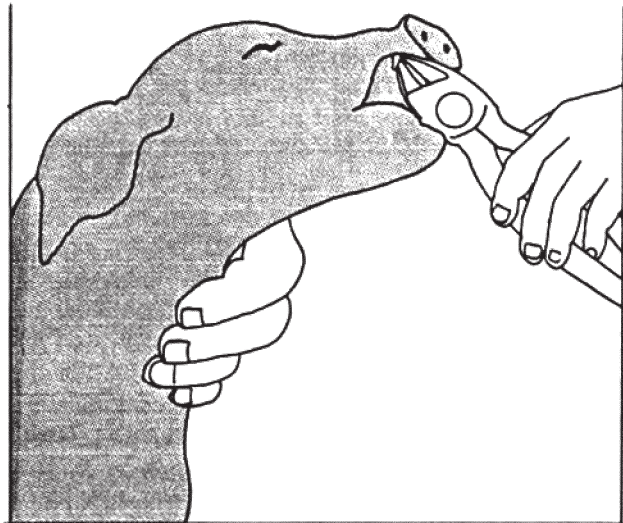

(From Tuskegee Inst. Circular TI-AS*14A)

Iron Deficiency Anemia in Baby Pigs—An unhealthy condition in baby pigs called **baby pig anemia** (lack of blood) is common in baby pigs, who do not have access to soil the first few weeks of life. It is caused by a lack of iron and copper which is **essential for blood formation**. Since sow's milk is deficient in both of these minerals, baby pigs **must have additional amounts**, or their chances of survival are very poor. Soil usually contains adequate amounts and the baby pigs, almost from the first day, will eat soil. If they are housed in buildings with floors they do not have access to soil and a method **must be found** to provide iron and copper.

The **simplest solution** is to bring soil to the pigs. Place it in a small container for each litter of pigs. **This adequately solves the problem**, but it should come from an area that **pigs have not had access to**. This prevents spread of parasites and disease germs to the pigs. This dirt should be replaced often.

Clay type soils (heavy and yellow) generally contain more iron than other types. If there is not enough iron in the soil, another source of iron, that has been used is **tomato juice**. Give the baby pig one tablespoon (large spoon) full twice weekly, starting at one or two days of age and continuing weekly until four weeks of age.

There are commercial injectable and oral products available for pigs and solutions to apply to the sow's udder. These are costly and often not available.

Anemic pigs have very poor resistance to infections, do not grow well, and many will die if an iron source is not provided by the end of the first week. It should be provided by the third or fourth day of age.

Pigs born on the ground should not have an anemia problem.

Feeding The Baby Pig—(See Notes on Nutrition).

Castrating (Testicle Removal) The Baby Pig—Pigs are castrated for several reasons: to prevent an unpleasant taste and odor in meat, to prevent the nuisance of the boars not needed for breeding, and some people think castrated males grow faster.

Under most primitive conditions, male baby pigs should be castrated around 2-4 weeks of age. Pigs withstand castration much better while nursing than after weaning.

The operator should be careful to have his hands and knife clean (and disinfected if possible). The scrotum (skin over testicles) should be washed (and disinfected), as well as the knife.

Hold the testicle firmly between the fingers and thumb. Make an incision through the skin and into the testicle, with a sharp knife. The incision should be parallel to and 1/4 to 1/2 inch off the midline of the scrotum. Separate the testicle from the surrounding tissue. Pull it away with the attached spermatic cord, and cut it off near the body. Remove

the other testicle in the same manner. Be sure the incisions are low enough for good drainage when the pig is standing; this speeds healing.

After the operation, blood should be washed from the skin near the incision. Blood will attract flies and infection may result. Insect larvae, such as screwworms, may infest the wound.

Wound spray or liquid (with fly repellent) applied around the wound is even better.

Often in the community, there is someone with experience in castrating pigs. His techniques should be observed. However, some of these mentioned suggestions might well be an improvement.

Keep the recently castrated pigs from dirty wallow areas and other unsanitary conditions, until wounds heal.

Common Mistakes in Castration—failure to clean and disinfect prior to the operation, incisions too small for drainage, incisions too high for drainage, wet and unsanitary living conditions before healing, and waiting until pigs are past weaning age.

There are many satisfactory **disinfectants** including iodine, alcohol, very weak solutions of chlorine laundry bleach, hydrogen peroxide, mercurochrome.

Weaning—Separating nursing pigs from their mother. This is one of the greatest stress periods in the pig's life. It is also a time of considerable stress on the sow.

In the natural state, sows usually wean the pigs themselves when pigs are around 8-10 weeks old.

In modern operations with confinement rearing, baby pigs are often weaned as early as 3-5 weeks of age. In **primitive situations**, without expensive buildings and sophisticated rations, **this is not necessary or wise to do**. Since sow's milk is the natural food for baby pigs, it should be used as much as possible. This means leaving pigs on the sow, until around 8 weeks of age. The quantity of milk starts decreasing at around 3-4 weeks after farrowing. Baby pigs should be started gradually on solid food at 10-14 days of age, and fed increasing amounts as they grow older, as the sow's milk is decreasing. If they are eating solid food well, there is much less digestive shock at weaning time, and fewer health problems in general. **(There is much more information on feeding Baby Pigs in the section on Nutrition.)**

The nursing sow should have her food gradually decreased, starting about a week prior to weaning. This will greatly lessen her milk production and lessen the chances of udder problems, following weaning.

Sow Weaning Problems—If, as occasionally happens, the udder becomes distended with milk a day or so after weaning, pigs can be allowed to nurse a few minutes every other day.

If the udder becomes "caked", (hard to the feel and often with a hot feeling), a simple remedy is to massage it daily with camphorated oil,

a common human remedy for bruises. If the sow should lose her appetite, she probably has an udder infection and fever. In this case she will need to be treated with antibiotics-(See Health Section)

Baby Pig Weaning Problems—These can usually be prevented by the following:

1. Continue pigs on feed that they are already used to, before weaning. By not changing the feed, we avoid one stress that often causes problems. After a week or so, the feed can gradually be changed.

2. Remove the sow and leave the pigs in their familiar surroundings for several days. This is a simple way to prevent another stress problem.

Weaning Age for Two Litters Per Year—Under most primitive conditions, two litters per sow per year is feasible. Consider that pregnancy length in the sow is almost 4 months, and that sows come in heat a few days after weaning pigs. This means no later than **8 week weaning** of the baby pigs, for two litters per sow per year. This is a very good time for the sow and baby pig.

A Big Decision—One or Two Litters Per Year Per Sow—While 2 litters per year should be tried for in most cases, there will be instances for various reasons where food for pigs is very limited at certain seasons. Sows might be on a maintenance ration and unable to sustain a normal pregnancy, and nurse pigs adequately. In that case, sows should be bred to become pregnant and farrow during the highest level of nutrition.

Another circumstance would be, when one season of the year is a long period of extreme weather. Maintenance of pregnancy and baby pig survival might be very poor.

Raising Orphan Pigs—Orphan pigs become a problem; when the mother sow dies, is sick and not giving milk, or occasionally when the sow has too many pigs and some must be taken away (generally over 12 in the litter).

Cow's milk is a satisfactory food for the newborn pig. Human baby bottles can be used but cleaning and sterilizing are a big problem. Pigs will usually drink from a shallow pan. They should be fed six times a day for the first two weeks, then gradually reduced to three times a day. At around 10-14 days, small amounts of bread scraps or cracked grain can be added and gradually increased, and the milk decreased over the next several weeks. **Goatmilk is less desirable**, but may be used.

Another possible solution, is to move pigs to sows with very small litters. This will only work if the orphan pigs are within a few days of the age of the other pigs. Very often the sow will reject the orphan pigs. This may be overcome by wetting the orphan pigs' backs with milk or a human skin medication, both of which would have an odor that would confuse the sow as to which were the orphan pigs.

SECTION ON THE GROWER-FINISHER (FATTENING ANIMAL)

A. General

After pigs have made the adjustment of weaning, they have passed the most critical stages of their life.

The Grower-Finishing-Fattening period is the period between that time and the time when they reach the desired slaughter or market weight.

It is that stage in their life when, if given reasonably adequate nutrition and protection from extreme weather, they should reach market or slaughter weight with very few problems.

It is the age when there are less critical nutritional and environmental needs. ***However, the fewer compromises that are made, the faster growing and healthier these animals will be.***

B. Nutrition of the Grower-Finisher Animal

This is well covered in the Section on Nutrition. The important point is that the needs of the pregnant and nursing sow and baby pigs must come first, if the amount and quality of food are in limited supply. This age animal may be stunted by inadequate nutrition but has a much better chance of surviving.

If the food is plentiful, they should be allowed to consume all that they will eat.

C. Environmental Consideration of the Grower-Finisher Animal

This was covered in general in the Section on Environment. However, there are a few things to keep in mind.

1. Where higher, well drained land is limited, or land has been heavily used by pigs for a long period of time, this age animal can best tolerate these conditions.

2. Where natural or man-made protection from extreme weather is limited this age animal can better tolerate these conditions.

Every possible effort should be made to provide satisfactory living conditions so that animals will be healthy, fast growing and the operation efficient. Animals subjected to excessive environmental stress will not efficiently use food, will grow very slowly, and develop health problems.

D. Length of Time to Reach Slaughter Weight

This will vary according to nutrition, environment, disease and health conditions, and the genetic makeup of the animal. Well bred animals on a balanced ration and satisfactory living conditions, often reach slaughter weight as early as 6-7 months of age. Under conditions less satisfactory, it may take as long as 12 months and unhealthy animals may never reach that point.

Factors in Growth Rate—The major limiting factor in growth rate, under most primitive-conditions, is a lack of protein in the diet and failure to control internal parasites (worms) and environmental stress.

Other factors, often involved, are mineral deficiencies and other nutritional problems along with many health and disease problems.

E. Castrating Older Pigs

As we mentioned earlier in the Section on Baby Pigs, castration should be done prior to weaning. For various reasons this may not have been done. It can be done at later times, but the risk is greater. The major problem is blood loss from the larger blood vessels and the greater risk of infection. Blood loss can be prevented by tying off the blood vessels, leading to the testicle, with a material such as small fishing line. This is a necessity in the case of older mature boars no longer needed for breeding purposes. Always use an antiseptic wound spray, containing an insecticide, to prevent screwworm and other fly problems.

F. Internal Parasite (Worm) Treatment and Control

Worm treatment and prevention is a necessary practice, if we are to produce healthy pigs. This topic is covered in detail in SECTION VII-Health Problems in Pigs

G. External Parasites (Insect) Treatment and Control

Another factor in producing healthy pigs is insect treatment and control. This topic is covered on pages 111-115.

Section V

Restraint and Handling Pigs

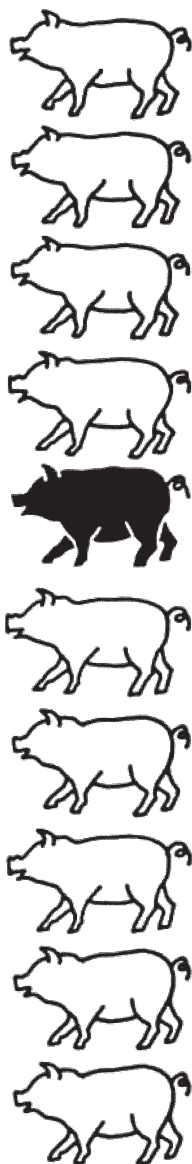

RESTRAIN-CATCHING-HANDLING-MOVING PIGS

For many reasons, there are times when pigs must be handled or restrained for vaccination, castration, drug treatment, weaning, moving, loading, and other situations.

First of all, we must realize that pigs are different from other animals in disposition, temperament, instincts and body design. Because of this, they must be handled and restrained differently. Different methods and equipment must be used.

Of the domesticated animals we usually work with, pigs still retain more of their natural survival instincts, and can be very unpredictable. Each animal is different, even those of the same litter.

They are easier to work with, grow better, and are usually healthier, if they are treated gently and given regular attention. If treated kindly and given regular attention, most pigs are very agreeable. Never forget, when excited or frightened, sows with baby pigs can be dangerous. Adult males should always be considered dangerous.

A pig's body is smooth, streamlined and tough, that enables him to work his way through vegetation. It is instinctive for him to spot a small opening and try to go through it, even a person's legs. This trait can be helpful in catching pigs.

Pigs are difficult to drive or pull, but often food can be used to get them to move from one area to another. They will usually follow a feed bucket that they are used to.

Pigs of all ages are very subject to heat stress in hot weather. For this reason, it is best to handle and move them in early morning or late afternoon. Avoid handling them roughly.

In the remainder of this section, we will discuss methods and equipment for handling pigs of different ages.

1. **Catching and Handling Small Pigs:** Grab the pig quickly from behind, grasp one or both hind legs, or with both hands grab the pig just behind the shoulders. The best way, is to grab the hind legs and quickly shift hands to hold him around the body. This is shown in the following drawing.

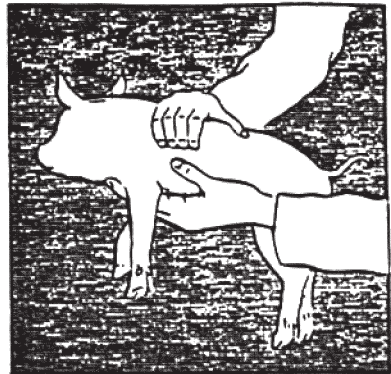

For treatment by the oral (mouth) route, pigs can be handled as shown in Figure 1. This method may also be used for injectable treatments and vaccination of the young animal. See Figure 1 below.

2. Catching and Handling Medium Sized Pigs (between weaning and 45 kg (100 pounds))

Grab the pig by the hind legs, lift them up so that feet cannot touch the ground, and squeeze between your knees. For most drug treatment and vaccination, the abdomen (belly) should be in the direction you face, as shown in the following drawing. See Figure 2. below.

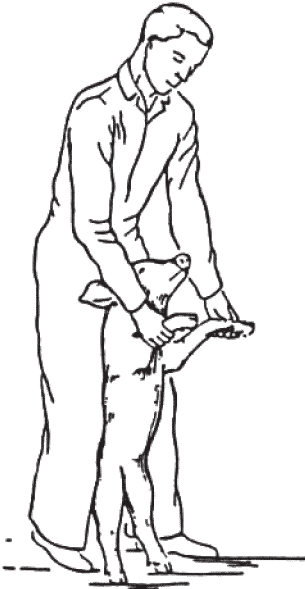

Figure 1



Figure 2

This same position, shown on next page, can be used for castration.

For oral (mouth) treatment of medium sized pigs, they may be caught by hand or with a snare rope. Then a person reaches over the pig from behind, and grabs both front legs at the ankle, and lifts the pig up and restrains him, as in the following drawing, No. 2 on next page.

Some people prefer this method of restraint for giving injections and vaccinations to this age pig.



Figure 1



Figure 2

3. Catching and Handling Large Pigs Over 45 kg (100 Pounds):

A large pig shut up in a small pen, can be caught with a snare rope or lariat type rope. These are so strong and their bodies so smooth, that they are very difficult to catch by the legs, although some people are able to do this. A snubbing rope is basic equipment. It needs to be at least ten feet long, with an eye in one end and the rope run through it to make a loop. To use it, stand behind the pig and place the loop over the pig's nose. If the pig does not open his mouth, the rope can be moved back and forth against his front teeth and into its mouth. It must be moved behind the tusks (large teeth), and the loop quickly tightened. Pull forward on the rope; the pig's natural reaction to pull backward, keeps the rope tight. The following drawings illustrate this very well.

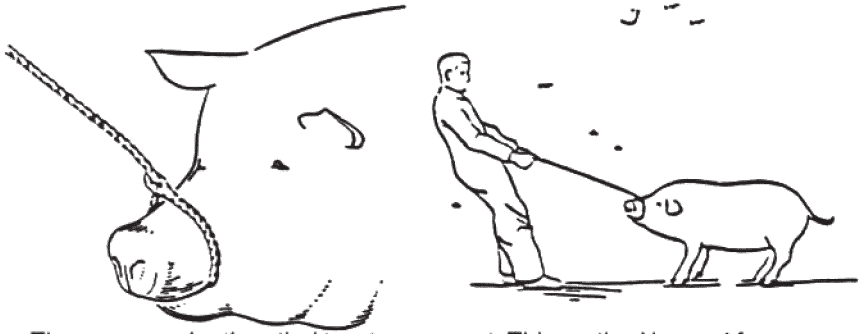

The rope may be then tied to a tree or post. This method is used for vaccination and treatment of adult pigs.

Snares-hog holders:

Catching pigs in a large pen may require a snare, which can be made from easily obtained materials. A 60-75 cm (24-30 inch) piece of 2.5 cm (one inch) pipe is the basis of it.

To one end of this pipe is fastened a length of rope or cable (old speedometer cable works well). The other end is passed through the pipe, leaving a loop at the end, to form the noose for catching the animal. With a quick stroke, the noose is looped about the pig's nose (snout) and pulled tight. The pig's natural instinct to back up, keeps it tight. It must be done quickly. It takes strength to hold a large pig. A small mound of feed or grain in a trough will attract the pig. It is often distracted while eating, and can be caught. It is best to work the **snare into the mouth and behind the tusks**. If the pig must be held for any length of time, the snare should be replaced with a snubbing rope. Two home-made snares are shown in the following drawings.

The first drawing is of a snare with a cable **fastened to the end of the pipe** this is the best method. The second drawing is improvised from a piece of pipe and a rope, and is only for occasional use. It may not be adequate for adult animals. Manufactured snares of this type are available in some countries.

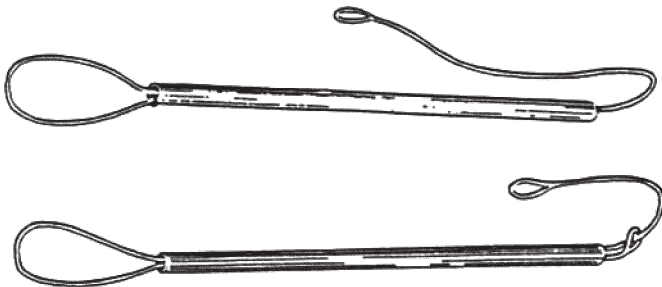

Casting: There are times when large adults must be tightly restrained, as in castration of males and other situations.

The pig is first secured with a snare or snubbing rope. Short ropes are then looped around front and back legs. The end of the rope from the back foot is carried over his opposite shoulder, and around a post at his head. The rope from the front foot is passed under the body, and across the opposite ham, and around a post at his tail. When the ropes are pulled tightly, the pig will fall. The ropes are then tied to post, close to the pig's body. This is usually all the restraint that is needed. However, if the pig struggles, the back legs may have to be tied together. The following drawing very well illustrates this simple method of casting pigs.

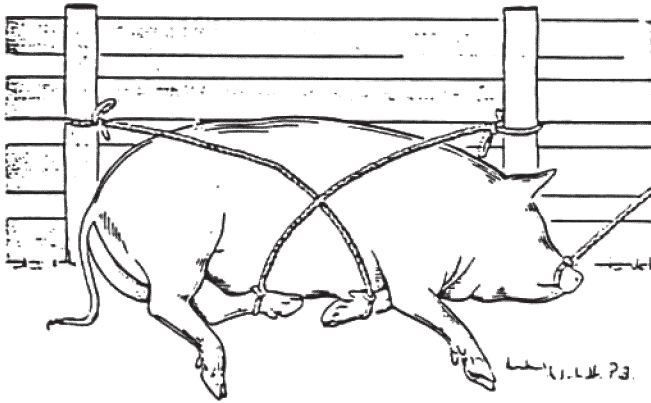

A very strong person may be able to throw a pig by reaching under the body and grabbing the opposite legs. The opposite legs are pulled toward the person and the pig will fall away. When the pig is down on his side, his feet may be tied or held down by several people.

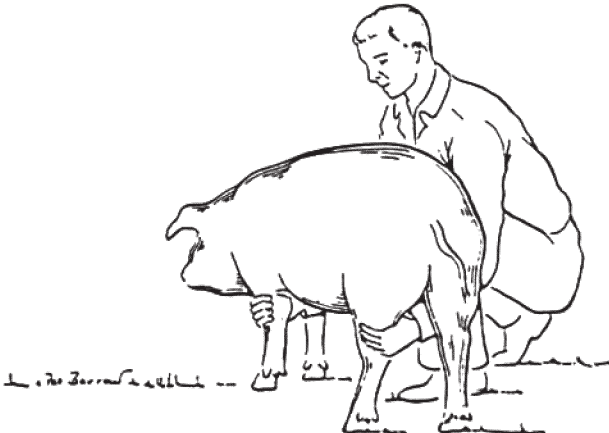

Moving and Loading Adult Pigs: A simple and usually successful method is based on the fact that pigs go backward more easily than forward. One person puts a bucket over the head and pushes backward, while another person pulls on the tail and guides the pig. This is shown in the following drawing.

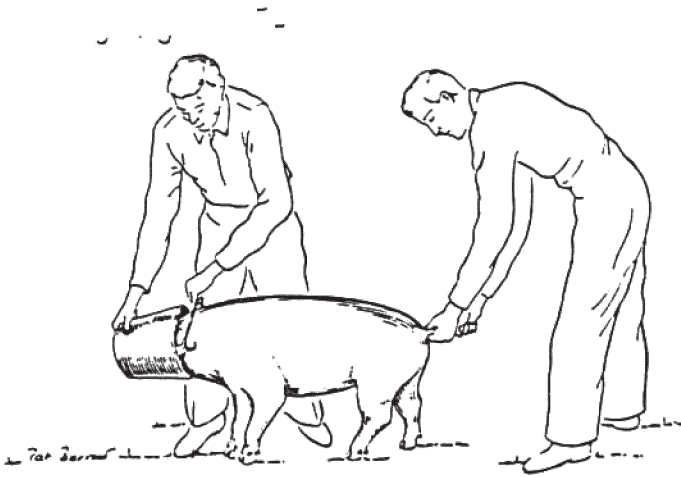

In some areas, pigs are trained to be led by a rope. This must be done at an early age. Usually, food is used to entice the pig to be trained. Being trained to the rope is helpful in moving animals to another feeding area, and females to be bred.

(This section was adapted from the book "Restraint of Animals", by John R. Leahy and Pat Barrow. Used by permission of Dr. John R. Leahy).

Section VI

Understanding Disease and Parasite Prevention and Control

Quote:

“Always assume that where feces and filth are found, disease causing germs, parasite ova and larvae, will also be found.

Assume that these organisms will live for months and even years, under those conditions.

Sanitation is a big word that simply means, doing all that we can to keep animals away from feces and filth.

This is one of the best things that we can do, to keep our animals healthy.”



UNDERSTANDING DISEASE AND PARASITE PREVENTION AND CONTROL

- A. Siting - location of the livestock unit
- B. Pen and Pasture Rotation
- C. Temporary - Movable Buildings for Livestock
- D. Birthing on Cleanest (Least Used Areas)
- E. Importance of Providing Clean Food and Drinking Water
- F. Other: Separation of Sick Animals
Quick Disposal of Dead Animals

Introduction: It is unlikely that all of the following suggestions will apply to any given area or situation. One or more can nearly always be used to improve livestock health and efficiency of production on most small farms. Labor is the primary requirement for making these improvements. A plentiful supply is available in most underdeveloped areas.

Most of these practices cost very little and are simple enough for most farmers to establish.

This book emphasizes pigs, but the background, concepts, and suggestions apply to other farm animals, including poultry.

A. **Importance of siting (Location)** of the livestock unit:

Pasture rotation, and the proper siting (location) of the livestock unit, are basic and essential practices to minimize disease and parasite problems.

Areas, where water stands for long periods of time, especially low wetlands, provide an ideal environment for the survival and spread of disease organisms and parasites. Avoid such areas whenever possible. Animals confined to such conditions are constantly exposed to disease and parasite infection, by drinking standing water. Free standing forms of parasites, which penetrate the skin and blood sucking insects that irritate and weaken animals, spread disease, are more plentiful and cause greater problems in wet areas.

Moving animals to higher, drier ground may require, construction of shelter for shade and wind protection. A new source of water may be necessary. These inconveniences will nearly always be compensated for by the improved health of the animals, especially when other practices in this section are added.

There are some areas, especially where acreage is limited, where wetlands must be used. Under such conditions drainage should be provided. Small, shallow ditches or trenches around pens or pastures will greatly improve sanitation, disease and parasite control.

The few problems associated with moving to higher, drier land is greatly offset by the improved health of the animals, especially if other practices in this section are used.

Line Drawing Illustrations Of Siting-Location of The Livestock Unit on Higher, Drier, Well Drained Land

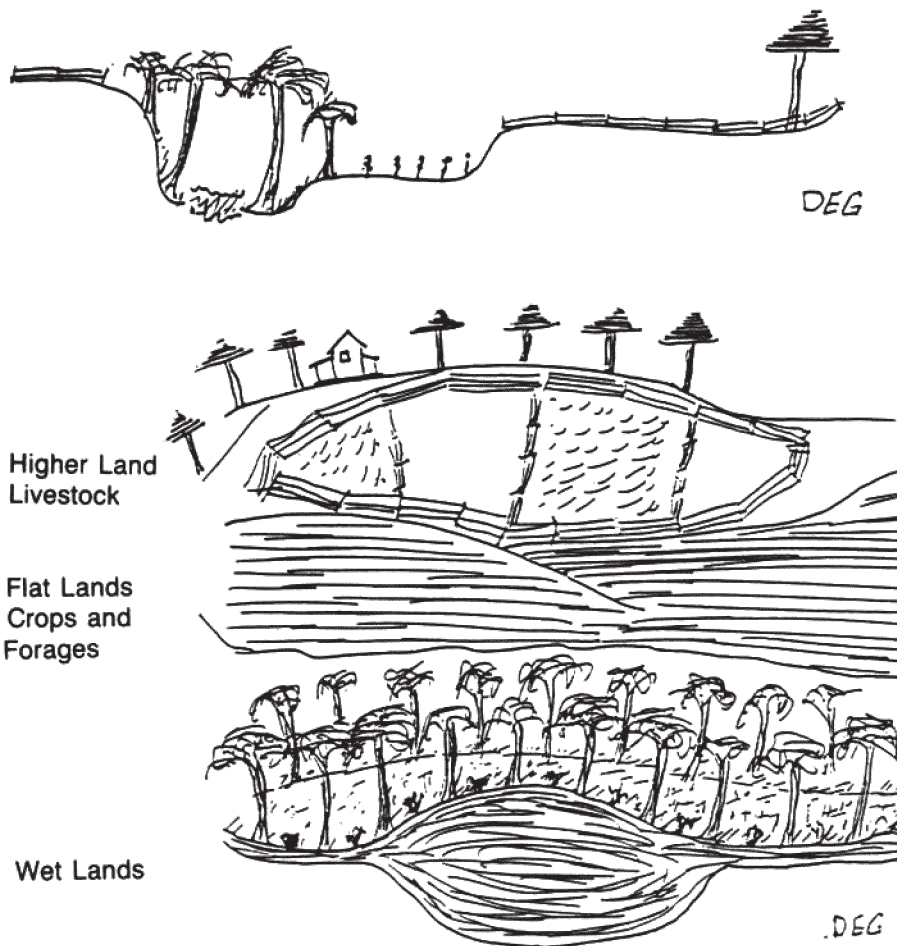

During non-crop season, animals could use cropland area and often are able to utilize foodstuffs left over from harvest.

B. Pen and Pasture Rotation:

As previously mentioned, one of the most important and necessary practices, in disease and parasite prevention, is that of pen and pasture rotation. This is a long used and well proven method that can and should be used by any livestock or poultry owner.

What we want to have the farm animal owner (and those who advise them) understand, is very simple. It is, ***“Always assume that feces and filth contain disease causing germs and worm eggs or larvae.*** You must assume these organisms can live for a long time in the soil. “If you can periodically move animals from an area that has been used to an area that has not been used for a period of time and leave the feces behind even for a short period of time, you leave the disease germs and parasites behind. This always improves the health of farm animals.

A pen or pasture or barnyard that has been continually used for many years, produces an environment in which it is impossible to raise healthy animals. Moving them to a cleaner area, if only a short distance away, results in dramatically improved animal health.

Usually, a double or “use one-rest one” system is most practical. **This allows for a decrease in the numbers of disease germs and parasite eggs in the soil over a period of time, when no animals are using the pen or pasture.** In some extreme situations, such as all lowland acreage or long and heavy use by farm animals, it may be necessary to use a triple system, where two pens or pastures are rested while one is being used.

A question arises, as to how long to rest an area before using it again, for farm animals. Ideally, two or more years would be desired but one year is of great benefit. Even six months rest is a big improvement. A few months rest often helps.

While “resting” and not being used by that species of animal, it could be used for other farming purposes. It is best not to use those resting pens or pastures for another species of livestock. But if necessary it can be done. Certain diseases and parasites could limit the use of those resting-rotated pastures and pens for some foods grown for human use such as ground vegetables.

Tethering, staking out, or use of small temporary pens or pastures to allow grazing or foraging, where other animals of the species have not recently used, can result in the improved health of animals.

It must be strongly emphasized that the old idea of a particular area being the **permanent long time** location for animals of a given species; ala “The Cow Pasture,” or “The Pig Pen,” or “The Chicken Yard,” almost always leads to serious health and growth problems. It should be discouraged.

In most instances, you will see an almost immediate improvement, if you can convince farmers to accept the idea of pen and pasture rotation. Even if the resting-rotation is only for a short period of time, improvement is seen. This is especially true if other practices in this section are used.

January to June
(Or Year One)

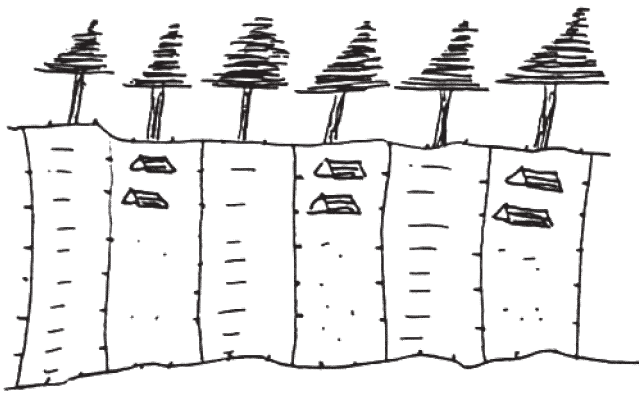

July to December
(Or Year Two)

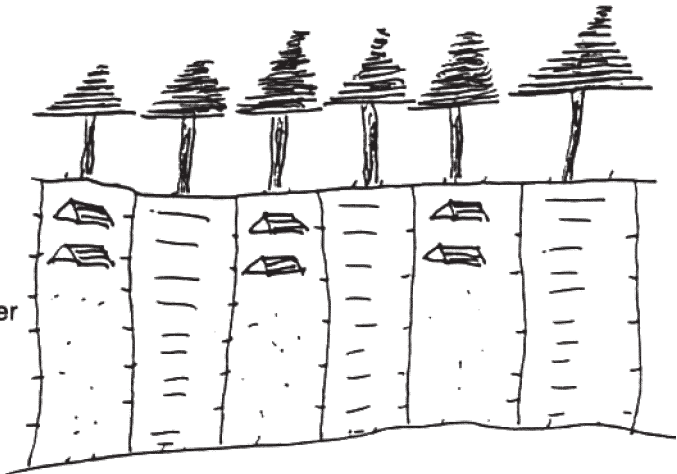

Double: Use one, rest one, rotation system for swine farrowing, using A-Frame portable farrowing houses. This system is preferred because every other pen or pasture is not used. This can be a barrier to the spread of diseases and parasites.

Note.: These illustrations are not intended to be a specific design of a swine operation; rather they are intended to illustrate the point of pasture and pen rotation in an easily understood way.

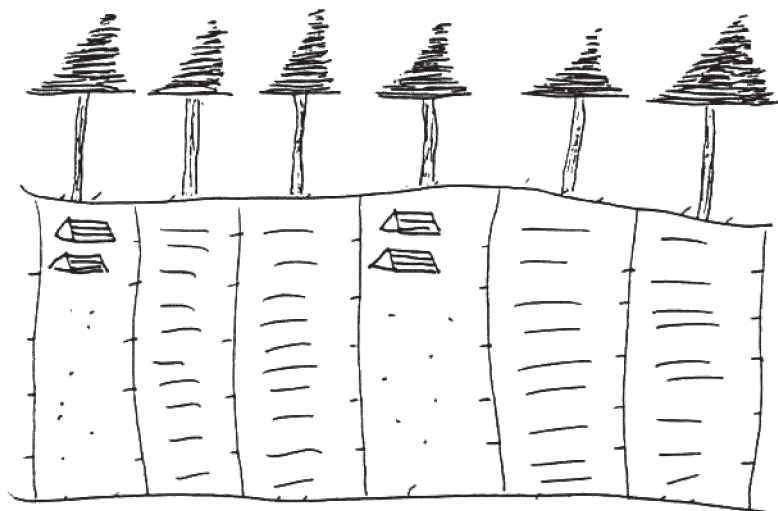

Triple-use one-rest two system of pen or pasture rotation for swine farrowing using A-Frame huts. This would be indicated more in cases where pastures or pens have been heavily used for a long time, or where land is low and wet, and disease or parasite problems have already arisen. In this system, two pens or pastures rest while one is used for livestock.

C. Animal Health Benefits Of-Using Temporary or Movable Buildings for Farm Animals and Resting of buildings (Not Using for Periods of Time)

Along with pen and pasture rotation, it would help most small farmers if they would stop using the same stables, sheds, or shelters for farm animals, over a very long time.

The buildup of feces, rotten bedding, waste feed and moist soil in continuously used buildings, shed, stables, etc. is a good environment for the survival and spread of disease germs, worm eggs and larvae. Continuous use of the same buildings of any kind, over a period of time, allows disease and parasites to cause health problems in animals, especially, the newborn and young. High moisture found in buildings and lack of sunlight, add to the health problems.

Simple, inexpensive, temporary or movable buildings, which are either moved or rested from time to time, or even abandoned, can lessen health problems in farm animals. This is particularly true of the area where birthing of the young is done, and the young are raised.

A good example of this principle is the A-Frame portable farrowing house for pigs (shown in an earlier section on buildings and equipment).

It is one of the most practical of any farm building, and it can be used almost anywhere. It is easily built by almost anyone from a variety of inexpensive or used materials. After farrowing and weaning of the baby pigs, it is simply moved a short distance away (at least fifty feet). By doing this, the feces and filth is left behind. Each farrowing is then done in an area where there have been no pigs for a period of time and the young are birthed into a healthy environment.

FOR THE SMALL FARMER RAISING ANYKIND OF FARM ANIMAL, THIS IS ONE OF THE MOST IMPORTANT IDEAS (TO EMPHASIZE), IN ORDER TO RAISE HEALTHIER ANIMALS.

While not as necessary in older animals, it is still important not to use the same area and buildings over a period of time, without resting or moving.

Under most small farm conditions, **floors in buildings used for farm animals sooner or later causes problems.** The buildup of feces and filth leads to health problems, especially in the newborn and young, unless buildings are kept very clean daily. Even then, it sometimes happens.

The exception is; where there is no high dry land for the young, or the amount of land is very limited. If floors have to be used, feces and filth have to be removed daily, cleaned and disinfected, when animals are moved out.

Note: Examples of temporary-movable buildings are shown in Section II part 3 (buildings and equipment).

D. Use Cleanest Areas (longest without animals) For Birthing of the Newborn

This is one of the most important methods to use to improve the health of animals. Yet, it is poorly understood by most who care for animals. It is one of those which almost any animal owner can put into practice. It costs very little.

On many farms, the same pen, or pasture, or stable, or shed, has been used for birthing for years. The newborn comes into a very unhealthy environment. It is all but impossible, to get a healthy start in life. Preventing or minimizing the exposure of the newborn to disease germs and parasites, at this most critical stage in life, often means the difference between a healthy, efficiently growing animal, or a sick, stunted, or dead animal.

If possible, we should use higher, drier land, that has gone the longest without animals, for birthing. If acreage is limited, one should use small areas of the highest, driest part of the farm, for this purpose. We would not use it for other age animals in order to limit the amount of feces with germs and parasites. We would not use the same

area for more than a year without a period of resting from animal use. If health problems are seen, we would want to move before more animals are birthed.

Where land and resources are limited, or it is low and wet, consider tethering, or staking, or temporary pens, just prior to birthing through weaning. This, almost always, results in improved health of the young, especially if this is done on land not lately used for animals.

This is one of those ideas every animal owner should consider and those that advise them understand.

E. Importance of Providing Clean Food and Drinking Water

As other practices mentioned in this section, this is one of those simple, basic but most important, health ideas that can make a big difference.

1. Importance of Clean, Fresh Drinking Water

Animals, and especially pigs, will drink whatever water is available. Contrary to most opinions, they prefer clean water and as a result are much healthier. As a factor in raising healthy animals, it is one of the most important things that we can do.

The risk of taking in germs and parasites, by mouth, in drinking water from ponds, groundwater or small streams, is to be avoided if possible. Often, other animals have urinated or defecated into or close to the water. It often does not taste as good as fresh water; it limits the amount they drink, and affects their health and growth.

Dependence on surface water alone often means seasonal problems, and the need for a better source. The nursing female, if she is to provide enough milk for her newborn, has a **great** need for water. **The young animal, as it begins to take in solid food, needs some clean fresh water.**

Closeness of water to the food source affects the amount of food eaten. If the source of water is a great distance away, some of the weight gain may be lost in the exertion getting to the water. Less food is eaten, if plenty of water is not available.

Fresh water available in a trough or other clean container, in a shady cool area, where animals have easy access, should be a priority. **While many things may work against this, any thing that we can do to help improve water quality and availability, should result in better overall health, and efficiency of growth.**

Drawings of water containers are shown elsewhere in this book.

2. Importance of Providing Clean Food by way of Troughs

Other Methods

The use of feeders to prevent animals from eating food on the ground provides many advantages.

Food eaten on the ground usually contains feces, which insures that disease organisms, parasite eggs, and larvae will be ingested with the feed.

Feeding on the ground increases the likelihood of spoilage. This will add to health problems. It increases the waste of feed.

Health factors and increased feed wastage should encourage farmers to eliminate, where possible, feeding on the ground for all species of animals, especially pigs.

Inexpensive and, surplus materials can be found on most farms to provide troughs, racks, and other feeders. Scrap lumber, metal, and tires are most often used, although concrete and dugout logs, may be more common.

Using feeders to eliminate feeding on the ground is a simple, basic method to further improve the health and growth of animals. Added to other management practices listed in this section, results can be dramatic.

Drawings of troughs and other containers for feeding swine are shown in another section of this book.

F. Other Considerations in Keeping Animals Healthy

1. **Separation of Sick Animals:** This is an important and often neglected practice that can slow, and even prevent, the spread of disease within a group of animals.

The quick removal of the first sick animals (or even better: move the healthy ones away from the sick) will lessen, and possibly stop, the spread of contagious diseases.

A good example is baby pig diarrhea. It is possible to prevent the spread of this disease by simply separating the sick animals from the well.

Whenever health problems are encountered, other animals should be excluded from the area. (For several months, if possible.)

2. **Quick Disposal of Dead Animals:** The immediate disposal of dead animals by burial or burning, like the separation of the sick from the well, is an essential practice to reduce or prevent the spread of diseases.

Burial and burning should be done some distance away from healthy animals. The disposal site for dead animals should be carefully selected, not only to stop the spread of diseases in animals, but to eliminate the possibility of infecting humans with certain diseases of animals.

3. **Environment (Living) Conditions**

Refer to Page 13, "ENVIRONMENT"

Section VII

Health Problems In Pigs

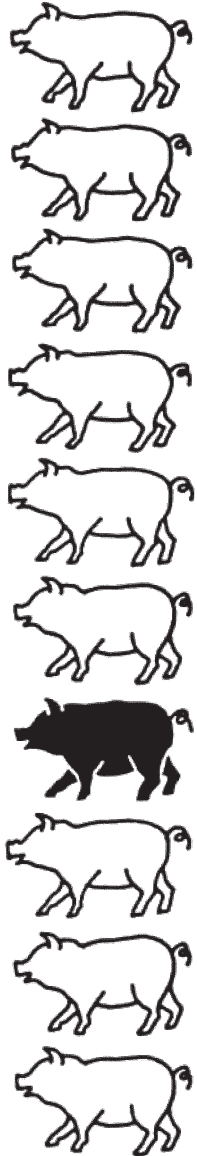

I. General Consideration in Prevention of Health Problems in Pigs

Health problems are costly to the farmer in reproduction, baby pig survival, stunting and death. Very often, stunted, slow growing animals are a major economic problem. They continue to eat but take a long time to reach market or slaughter weight. Some never reach that point.

Veterinarians are often not available for assistance and medications to treat sick animals, and even if available, it is extra expense. Sick animals that are treated successfully and recover, usually are stunted. They take longer to reach slaughter weight.

For these and other reasons the farmer should try to prevent health problems.

This booklet will concentrate on an understanding of the potential problems, and ways to prevent them. A detailed description of all possible diseases is beyond the scope of this booklet. However, a few of those that deserve particular attention are discussed.

A. **Sanitation**, or cleanliness is the first rule in profitable livestock farming. The commonly held ideas that pigs are naturally dirty and prefer muddy wallow holes, dirty pens, stagnant drinking water, and swampy pastures is wrong. In fact, that belief has led to many unnecessary and serious health problems in pigs.

Wherever there is fecal material (animal waste-manure) there are almost always germs and worm eggs. Germs and worm eggs survive well, where there is moisture and a lack of sunlight. Therefore, anything we can do in the way of a good sanitation program help toward preventing many health problems.

The following are suggestions for **Basic Sanitation**.

1. **Locate** pens and pastures on **highest, well drained land**.
2. **Rotate** pens and pastures often, leave them unused. This allows germs and worm eggs to decrease. **Nursing sows and baby pigs should be placed on cleanest land** (and without pigs on it).
3. **Food and water** should be placed in troughs or containers. Otherwise, pigs may ingest germs and worm eggs from the soil as they obtain food and water.
4. Building should be cleaned often with soap and water, and soiled bedding material replaced. As the buildings are emptied they should be cleaned well. (**See later notes on Disinfectants**).

Temporary (moveable) buildings should be moved often. This is a great help in reducing the number of germs and worm eggs that pigs are exposed to. **It is important to move the buildings and leave the filth.**

Since buildings with floors are so hard to adequately clean and disinfect, they should only be used under certain conditions such as in areas with extreme cold weather. See earlier notes in Environment Section.

Disinfectants (Germ killing chemicals) for use around pig facilities;

Commonly available products:

1. **Lye**—(Sodium hydroxide). Mix 0.45 kg (one pound) in 10 gallons of water; it kills most germs, but is dangerous to use if precautions are not taken. **Because it can cause skin burns and serious problems to eyes and internally, it should be used with care.** Use RUBBER GLOVES, EYE GOGGLES AND BOOTS, IF POSSIBLE.

2. **Household Chlorine Bleach** diluted according to directions on the bottle is a satisfactory germ killer. **Use with care.**

There are *many* commercial disinfectants available. They are costly, and in most primitive situations, their use is not practical. In other cases, the sanitation measure previously outlined are usually satisfactory.

Note: If feed or water containers have been disinfected, they should be rinsed well, prior to being used again.

B. **Nutrition:** This was well covered in the **Section on Nutrition**. However, one cannot overemphasize the importance of good health and resistance to infection.

C. **Weather Stress:** Protection from extremes of hot and cold weather, whether by natural or artificial means, is very important in maintaining good health and resistance to infection. Weather stress can lower resistance, and lead to serious problems. **Refer to earlier Notes in the Environment Section.**

D. **Vaccinate,** against diseases that are a problem in the area. Consult with University Agricultural Staff or Government Veterinarians or others knowledgeable on animal health, in your area. They can help locate a source of vaccine and demonstrate their use. **There are General Notes in the Disease Section later.**

E. **Treat for Parasites**—While this will be covered in detail in the **Section on Parasites**, it is well to emphasize the importance of parasite control in maintaining health and resistance to infection. **Parasite (worm and insect) prevention, control and treatment are major factors in good health.**

II. **Understanding the Normal Healthy Pig and Recognizing Signs of Health Problems (Symptoms)**

The more that you know about the basic nature of the pig, the more likely you are to raise healthy pigs.

If you are to recognize the sick pig, you must first know how the normal healthy pig acts.

Pigs should be observed more as a group than as individuals, because most diseases and other conditions, generally affect several animals. They should be observed while quiet, rather than when you are working with them and moving them.

A. **Disposition**—The normal pig is a very curious, alert animal that

will constantly be poking around and interested in observing any approach to the pen, by people or other animals.

The sick pig will appear dull and listless, with a lack of curiosity. Often he is reluctant to get up and move around, even if forced to. It may be weak and uncoordinated.

B. Appetite—Lack of appetite is one of the earliest and most consistently recognizable signs of sickness. It is often a sign of fever from infection, and disease.

C. The recent bowel movement (fecal material) is a good indication of a health problem. A hard consistency can mean fever. Loose consistency (diarrhea), usually means an intestinal problem. Most often an infection. It is often caused by *intestinal worms*. At times it may be caused by *nutritional* problems, such as sudden changes in the diet. Various poisons may cause diarrhea.

D. Normal Respiration (breathing) is a smooth in and out movement by the muscles of the rib area. Any interruption of that smooth pattern, such as a jerky movement, coughing, or sneezing is an indication of a respiratory problem. The normal respiratory rate (breaths per minute) in the pig, ranges from **10-18 per minute**. A rate in excess of that, usually indicates a problem.

Bronchitis is a mild respiratory problem usually indicated by a faster than normal respiratory rate, and a slight change in breathing patterns. A slight cough is common. Sneezing may be seen. It is a symptom of a mild lung problem.

Pneumonia is a more severe respiratory problem, as evidenced by a very noticeable interruption in the breathing pattern, and a much faster respiratory rate. Often there is a harsh cough. It is a symptom of a severe lung problem, an obviously sick animal.

Discharges from the nose and eyes are recognizable signs of respiratory problems and often occur at the same time.

Respiratory problems have *many causes*. The most likely is chilling and overheating. Lungworms damage lung tissue and allow germs to cause an infection. Pneumonia and bronchitis often follow a high fever from other infections. Generally, unhealthy pigs from parasitism and nutritional problems often develop respiratory problems.

E. Normal Body Temperatures in the pig is 38.8-39°C (102-103°F). When environmental temperature is very high, the normal pig's temperature may be as much as 39.3°C (103.5°).

Fever is a higher than normal body temperature. It is usually the response of the body to an infection, and is a sign that the body defenses are responding to that infection. Under normal environmental conditions, a body temperature over 39°C (103°F) is considered to be sign of fever. During very hot weather 39.6°C (104°F) is considered to be

a sign of fever. **Body temperature in the pig is checked by using a rectal thermometer held in the rectum for at least 3 minutes.** The animal has to be very tightly restrained during this procedure.

Checking the body temperature is a simple procedure that should be used when we have sick pigs. It is a fairly reliable indicator of whether or not we are dealing with infection-disease.

A reddish-purple discoloration of the skin may be an indication of fever.

F. **Color of the mucuous membranes** (lining of mouth and nose and inner eyelid) are a good indication of a pig's health. The normal healthy color is reddish-pink. A pale to white, bleached out color indicates anemia (lack of blood). Baby pig anemia was previously discussed in the Baby Pig and Reproduction Section.

There are many causes of anemia, especially parasites and nutrition. Icterus Jaundice)-an orange to yellow color may be seen. It can be an indication of a number of conditions: infections, blood parasites and poisons that destroy blood cells.

G. **Problems with Locomotion** (movement) show up in several ways:

Arthritis—sore, stiff, swollen joints and a reluctance to get up and move around—usually caused by mineral deficiencies, infections, (diseases as Erysipelas) and injuries.

Foot Problems—sore, swollen feet and a reluctance to place weight on affected limb—usually caused by injuries, infection and diseases such as Foot and Mouth Disease.

“Downer” animals—(animals completely unable to get up)—This is usually seen in pregnant and nursing sows and most often is caused by a mineral deficiency. It may also be caused by a severe back injury.

Weakness and Uncoordination—are usually secondary to other serious conditions such as infection, disease, poisoning, etc.

III. **Major Cateaories of Health Problems and Their More Probable Causes:**

A. **Reproductive Problems** as evidenced by poor conception, and late abortion, weak and stillborn pigs and small number of live healthy pigs farrowed.

Causes: 1. General Poor Health Boar and Females.

- a. **Nutritional** problems such as a poorly balanced ration and deficiencies of necessary nutrients.
- b. **Parasites**—Failure to prevent and treat.
- c. **Chronic Diseases** such as non-fatal pneumonia and diarrhea.

2. **Stress of high environmental temperatures** on boar and females.
 3. **High Fever** in boars and females from infection and major diseases.
 4. **Reproductive Diseases** such as brucellosis and leptospirosis and others.
 5. **Boars or Females** too young at breeding time and mating (breeding) boars too often in a short period of time.
 6. **Injuries** to pregnant females.
 7. **Failure** to assist at farrowing time.
- B. **Poor Baby Pig Survival**—as evidenced by deaths and severe stunting in baby pigs.
- Causes:**
1. **Poor Milking in Sows** —one of major causes.
 - a. **Nutritional Problems**—prior to farrowing and while nursing pigs. (**See Notes on Nutrition of Pregnant and Nursing Sows**). **This is the cause.**
 - b. **Fever** in the sow usually causes milking problems.
 - c. **Udder infection** causes milking problems and milk may make pigs sick.
 - d. **Heat stress** on the sow, as in poorly ventilated buildings, and anytime the sow is not given protection from high environmental temperature, will probably cause milking problems.
 2. **Scours**—(Diarrhea—Loose bowel movement)—another major cause.
 - a. **Poor Sanitation** in the farrowing area often leads to infections and is a major cause of scours.
 - b. **Milking Problems** in the sow may cause scours.
 - c. **Chilling** results in loss of resistance to infection.
 - d. **Baby Pig Anemia**.
 - e. **Internal parasites**—worms.
 3. **Intestinal Diseases**—bacterial and viral infections such as salmonellosis, TGE, and others.

4. **Pneumonia**—respiratory problems caused by most of the same causative factors of scours, especially chilling.
5. **Major Diseases** Hog Cholera, Erysipelas, Foot and Mouth Disease and others which cause high death losses in all ages.
6. **Failure to provide solid food** to supplement the **sow's milk. This can contribute** to slowed growth and less resistance to infection. It also adds to the stress of weaning.
7. **Weaning Stress** is often a major cause of health problems. It was well covered in the **Baby Pig Section with Reproduction.**

C. **Stunting**—slowed growth in the growing-fattening animal after weaning. It may be a minor problem where the animal takes longer to reach slaughter weight or such a severe problem that animals will never reach that point. **It is one of the most common and serious economic problems to a swine farmer.**

Causes: 1. **Nutrition**—The major cause in most cases. It may be from a lack of food in general but most often is caused by a **lack of protein in the diet.**

2. **Parasites**—internal parasites (worms) are the other major cause of stunting in most cases. This is covered in detail in **The Parasite Section.**
3. **Continuation of Any Baby Pig Problems** that weakened but did not kill. Often the lung damage from pneumonia, intestinal damage from worms and scours and liver damage from worms causes long term effects leading to stunting.
4. **Non-Fatal Diseases and Infections** such as Pneumonia and Diarrhea that cause long term effects in survivors.
5. **Environmental Stress** such as extremely hot or cold weather with poor protection.
6. **Non-Fatal Poisoning.**

D. **Major Death Losses** in animals after weaning.

Causes: **Major Infectious Diseases** such as Hog Cholera, Erysipelas, Foot and Mouth Disease and African Swine Fever.

2. **Common Infections** such as Pneumonia and Diarrhea in animals not adequately treated for these common problems. Inadequate nutrition, and parasites often are the cause of the already weak animals.

3. **Poisoning**—There are many causes of poisoning in swine. While not a common problem it is serious when it does occur. Treating poison cases is expensive and results are usually poor.

IV. Basic Information on Treatment of Pig Health Problems

In this revised edition we are including some very basic information on treatment of the most often seen pig health problems. Many suggested it would be a big help to them. Writing on this subject is very difficult because of a number of factors:

- a. Conditions that appear the same may be caused by many different things and treatment for each is difficult.
- b. Most health problems are caused by a combination of several different things; for example, pneumonia often follows chilling or overheating and may be complicated by lungworms. Diarrhea is caused by poor nutrition, intestinal parasites, bacteria and viruses. The cause of health problems varies in different areas.
- c. Drugs are supplied in many different forms. Concentrations, mixtures and labels vary in different countries.
- d. There are special considerations and precautions for each age animal, especially pregnant females and newborn pigs.
- e. Often disease causing organisms have developed resistance to drugs. Drugs effective in one area may not work in another area.
- f. Drugs remain in the body for varying lengths of time, some for over a month. Some may cause problems if humans eat meat with the drug still in the animal's body. ***For this reason, one should always know the withdrawal time, before slaughter, of each drug used.***
- g. ***Caution: Government regulations regarding the use of drugs in food animals are in effect in most countries and should be followed very closely. For this reason, one should use extreme caution with drugs in food animals. Read labels closely regarding withdrawal (WAITING) time before slaughter. Do not use drugs not recommended for swine. If possible, try to obtain assistance from someone trained in drug use.***

DOSE CHART

CRYSTICILLIN (pencillin) - 10,000 u/lb.

Baby pigs:		1/4 1/2 cc inject daily IM
9 kg-22.5 kg	20-50 lbs:	1-2 cc inject daily IM
22.5 kg-45 kg	50-100 lbs:	2-5 cc inject daily IM
45 kg-99 kg	100-220 lbs:	5-7 cc inject daily IM
99 kg-225 kg	220-500 lbs:	7-12 cc inject daily IM

*withdraw 5 days prior to slaughter

FLOCILLIN (long acting pencillin) - 10,000 u/lb.

Baby pigs:		1/4-1/2 cc inject every 3rd day IM
9 kg-22.5 kg — 20-50 lbs:		1-2 cc inject every 3rd day IM
22.5 kg-45 kg — 50-100 lbs:		2-5 cc inject every 3rd day IM
45 kg-99 kg — 100-220 lbs:		5-7 cc inject every 3rd day IM
99 kg-225 kg — 220-500 lbs:		3-12 cc inject every 3rd day IM

*withdraw 30 days prior to slaughter

COMBIOTIC (pencillin + dihydrostreptomycin) -

Baby pigs:		1/4-1/2 cc inject daily IM
9 kg-22.5 kg — 20-50 lbs:		1 cc inject twice a day IM
22.5 kg-45 kg — 50-100 lbs:		1-2 1/2 cc inject twice a day IM
45 kg-99 kg — 100-220 lbs:		2 1/2-3 1/2 cc inject twice a day IM
99 kg-225 kg — 220-500 lbs:		3 1/2-5 cc inject twice a day IM

*withdraw 30 days prior to slaughter

POLYFLEX (ampicillin) - 5 mg/lb. (diluted 25 mg/cc)

Baby pigs		
1-2 days:		1-2 cc inject daily IM
2-4 days:		2-3 cc inject daily IM
4-10 days:		3-4 cc inject daily IM
9 kg-22.5 kg — 20-50 lbs:		5-10 cc inject daily IM

*withdraw 6 days prior to slaughter

GENTOCIN (gentamycin)-dose is 1-2 mg/lb once a day for

Baby pigs
-concentration is 5 mg/cc
3 1/2 lb (1.6kg) pig would receive
1-2cc intramuscularly once a day for
3 days

FOR LARGER PIGS

GENTOCIN (gentamicin) - 5 mg/lb (50 mg/cc concentration)

9 kg-22.5 kg — 20-50 lbs:	2-4 cc inject daily IM
22.5 kg-45 kg — 50-100 lbs:	4-10 cc inject daily IM
45 kg-99 kg — 100-220 lbs:	10-15 cc inject daily IM

*withdraw 40 days prior to slaughter

LA-200 (long action oxytetracycline) - 9 mg/lb.

Baby Pigs:	1/4-1/2 cc inject every 3-7 days
9 kg-22.5 kg - 20-50 lbs:	1-2 cc inject every 3rd day
22.5 kg-45 kg - 50-100 lbs:	2-4 cc inject every 3rd day
45 kg-99 kg - 100-220 lbs:	5-10 cc inject every 3rd day
99 kg-225kg - 220-500 lbs:	10-15 cc inject every 3rd day

*withdraw 28 days prior to slaughter

LINCOCIN (LINCAMYCIN) 5mg/lb (100 mg/cc concentration)

Baby pigs	$\frac{1}{4}$ - $\frac{1}{2}$, cc inject daily IM
9 kg-22.5kg — (20-50 lbs)	1-2 cc inject daily IM
22.5 kg-45 kg — (50-100 lbs)	2-5 cc inject daily
45 kg-99kg — (100-220)	5-10cc inject daily IM
99kg-225kg — (200-500 lbs)	10-15 cc inject daily IM

*withdraw 2 days prior to slaughter

TYLAN 50 (tylosin) 7 mg/lb

Baby pigs	1-2 cc inject twice daily IM
9 kg-22.5 kg — (50-100 lbs)	2-5 cc inject twice daily IM

TYLAN 200 (tylosin) 7 mg/lb

22.5 45 kg — (50-100 lbs)	1-2 cc inject twice daily IM
45 kg-99kg — (100-220 lbs)	1-5 cc inject twice daily IM
99 kg-225 kg — (220-500 lbs)	5-15 cc inject twice daily IM

*WITHDRAW 14 days before slaughter

BABY PIG TREATMENTS: The following are basic treatment suggestions. However, there are many different ways of treating any problem.

1. **Lameness, toe or claw injuries, swollen joints and umbilical infection.**

- Crysticillin — treat for three days by injection
- Flocillin — one injection every 49 hours
- Lincocin — treat for three days by injection
- Naxcel or Excenel (cetiofur) — 50 mg/cc inject 1 cc/10-16.8 kg (22-37 lbs) by the IM route once a day for lameness

2. **SCOURS (DIARRHEA)**

INJECTABLE MEDICATION-treat the entire litter for 2-3 days.

- Tylan 50
- Gentocin
- Polyflex (ampicillin)
- Naxcel

ORAL MEDICATION FOR DIARRHEA

There are many oral antibiotic combinations commercially prepared for baby pig scours and the entire litter treated if one is sick.

3. **BABY PIG PNEUMONIA**

- Tylan 50 for three days by injection
- LA-200 (terramycin) every 3 days by injection
- Crysticillin — treat daily for 3 days by injection
- Combiotic — treat daily for 3 days by injection
- Naxcel — treat by injection once daily

4. **BABY PIG ANEMIA** - inject 1-2cc (100 mg/cc) of iron dextran at 3-5 days of age; repeat at 14-21 days if still on floored pen.

*there are newer products coming onto the market which require only the first injection

There are oral (by mouth) commercial preparations available but they are not as effective as pigs may fail to swallow the product

IN EMERGENCIES CLEAN DIRT-preferably clay (heavy yellow soil) AVAILABLE TO PIGS FOR INGESTION in the pen.

Also Tomato Juice can be used-See Section VII-14.BABY PIG ANEMIA NOTES of Basic Confinement app-page 131

5. **Weak, starving newborn pigs and nursery age pigs:**
 - 30 ml - 2 TBSP syrup in one gallon of water as drinking water.
 - fresh or prepared powdered or canned milk at body temperature.
 - Sugar in water (5, 10, 50%) as drinking water. Offer all of these energy solutions free choice or in a drinker.
6. **Skin Infections (dermatitis) treat early**
 Apply standard Tincture (%7) Iodine to lesions
 inject Crysticillin daily for three days
 or Inject Flocillin (long acting) every two days
7. **Facial skin infections (dermatitis) from fighting with tusks.**
 Cut needle teeth first day as described in baby pig management section.
 Apply standard Tincture of Iodine
 Inject Crysticillin or Flocillin if severely affected.

TREATMENTS FOR OLDER PIGS AND LARGER GROWING ANIMALS

1. **Lameness, Arthritis, joint swelling:**
 - Flocillin every 48 hours by injection
 - Crysticillin daily for 3-5 days by injection.
 - Lincocin twice daily for 3-5 days
2. **Diarrhea (scours)**
 - Neomycin-Terramycin in drinking water for 5-7 days. Follow label directions for mixing.
 - Sodiamsulfathiazole in drinking water for 5-7 days. Follow label directions for mixing.
 - Injectable LA200; two injections at three day intervals.
3. **Acute Pneumonia.** many animals sick, off feed, extreme breathing difficulty, -high fever. Injectable Flocillin or LA200 every 48 hours
4. **Chronic Pneumonia:** animals sick several weeks or more, stunted but most continue to eat.
 - Injectable LA 200
 - Injectable Tylan 200 -Injectable Lincocin
 - Sodium Sulfathiazole in drinking water, mix according to label directions.
 - Injectable Lincocin
 - Soluble Terramycin in drinking water, mix according to label directions.

All treatments for chronic pneumonia must be continued for at least one week.

(This section was adapted from information supplied by Dr. Gordon L. Cop-poc and Mr. R. Kinsell of The Department of Veterinary Physiology and Pharmacology at The Purdue University School of Veterinary Medicine.)

INJECTION REFERENCE CHART

SUBCUTANEOUS (SQ): *Deposits the Drug Under the Skin:*

- ▶ Inject only into clean, dry areas.
- ▶ Use the loose flaps of skin in the flank and elbow of small pigs.
- ▶ Use the loose skin behind the ear of sows.
- ▶ Slide needle under the skin away from the site of skin puncture before depositing the compound.



Correct Injection Techniques:

- ▶ Ensure proper restraint of the animal prior to injection.
- ▶ Ensure proper syringe adjustment.
- ▶ Ensure proper needle placement onto the syringe.

INTRAMUSCULAR (IM): *Deposits the Drug Into the Muscle:*

- ▶ Use a spot on the neck just behind and below the ear.
- ▶ The neck area should be used for IM injections.
- ▶ Damage to the ham can result in condemnation of the meat cut.
- ▶ Use proper needle size to ensure medication is deposited in the muscle.

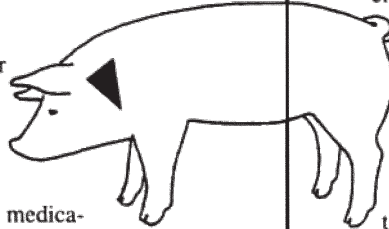

- ▶ Avoid swelling and/or abscessation at the injection site.
 - Use properly cleaned needles.
 - Inject only into clean and dry areas.
 - Prevent contamination - don't use the same needle to inject pigs and remove product from multi-dose vials.

INTRAPERITONEAL (IP):

- ▶ Should be used only upon veterinary instruction and guidance as serious injury to abdominal organs, can occur.

- ▶ Consult with your veterinarian about potential adverse drug and vaccine reactions.

Consult product label for approved routes of administration

INJECTION REFERENCE CHART

Intramuscular Injection		
	Gauge	Length
Baby Pigs	18 or 20	$\frac{3}{8}$ " or $\frac{1}{2}$ "
Nursery	16 or 18	$\frac{1}{4}$ " or $\frac{3}{8}$ "
Finisher	16	1"
Breeding Stock*	14 or 16	1" or $1\frac{1}{2}$ "
<i>* depends on backfat depth and method of restraint</i>		
Subcutaneous Injection		
	Length	
Nursery	$\frac{1}{2}$ "	
Finisher	$\frac{3}{4}$ "	
Sows	1"	

Avoid Bent or Broken Needles:

- ▶ Ensure proper restraint of the animal prior to injection.
- ▶ Replace bent needles as they are prone to breaking.
- ▶ Replace needles every 20 pigs.

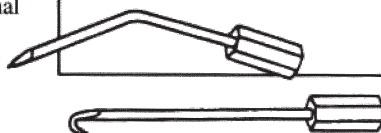

THIS MATERIAL PROVIDED COURTESY OF NATIONAL PORK PRODUCERS COUNCIL, USA AND PFIZER ANIMAL HEALTH, USA

V. Internal Parasites and Their Role in Health Problems of Pigs

Internal parasites (worms) and external parasites (insects) are a major cause of health problems in pigs. Because they are so serious you need to have a good background knowledge of these parasites, the problems that they cause, how to prevent and treat animals for them.

A. **Getting to Know the Worms**—Pigs are parasitized by many species of worms. Their ordinary living conditions, low wet, unsanitary areas and rooting in soil, favor survival and spread of worms. All the species of worms that infest pigs are major or contributing factors to stunting, poor utilization of foodstuffs, lowered resistance to disease and general poor health. They come in various sizes from the thread-like strongyloides to the pencil size ascaris. They are located in:

1. The ***stomach and intestine***:

Ascarids—Large roundworm.

Oesophagostomum—Nodular worm.

Strongyloides—Threadworm.

Trichuris—Whipworm.

Hyostromylus—Red Stomach worm.

Ascarops—Thick stomach worm.

Macracanthorhynchus—Thorny Head Worm.

Spiruroids—several species, (Ascarids, Physocephalus, Gongylonema) of small stomach and intestinal worms that migrate through the liver and cause intestinal irritation and stunting.

There are other stomach and intestinal worms in various parts of the world that parasitize pigs but they are usually similar to the ones being discussed.

2. Three species of ***Lungworms*** infest swine; two species ***Metastrongylus*** and one species of ***Chonostrongylus***.

3. In the kidney area, ***Stephanurus***, the kidney worm of the swine, is often a serious problem. They also cause severe liver damage.

4. **Flukes**: A type of flatworm common in many parts of the world, usually low wet swampy areas.

Fasciola—common liver fluke

Paragonimus—lung fluke

5. **Tapeworms and Trichina** are under some circumstances a **possible danger to humans** and will be discussed separately.

B. THE EFFECT OF WORMS ON A PIGS HEALTH depends on the species of worm and its location in the body. Worms add to the problems in animals already weakened by poor nutrition and other health problems.

STOMACH AND INTESTINAL WORMS cause irritation to the lining of these areas and lead to digestive upsets, diarrhea, poor utilization of food and stunting. Many species cause their major damage by sucking blood and lowering resistance to other health problems. Some species cause damage to the liver and lungs by migration of immature stages throughout the body. All of these are very serious to the baby pig and to older animals as well.

LUNGWORMS develop in the small air passages of the lungs and set up an irritation which interferes with normal lung function and often leads to bronchitis and pneumonia. This causes the animal to be unthrifty and stunted. Affected animals have a harsh cough.

KIDNEY WORMS in their immature stages, migrate through the liver and cause severe damage. They, then migrate to the kidney area, and cause severe irritation. Since the kidney and liver are such important organs, this causes the animal to be stunted and unthrifty.

LIVER FLUKES cause damage to the liver by irritation and blocking bile passages. Liver damage leads to stunting and general unthriftiness and poor resistance to disease.

LUNG FLUKES cause irritation to the lungs and secondary effects similar to lungworms.

ALL OF THE ABOVE SPECIES OF INTERNAL PARASITES(WORMS) CAUSE STUNTING, POOR FEED EFFICIENCY, AND GENERALLY POOR HEALTH.

C. LIFE CYCLES OF THE WORMS:

All of these worms pass part of their life cycle, ***OUTSIDE THE PIGS BODY. KNOWING THIS, IS THE KEY TO PREVENTION AND CONTROL.*** You must try to interrupt the life cycle and prevent spread from an infested animal to a healthy animal. All of these worms have adults in the body that lay extremely small (much smaller than we can see) eggs and are eventually passed out of the body in fecal waste (stomach and intestinal worms); coughed up, swallowed and passed in the feces (lungworms and lung flukes), and through the urine (kidney worms). The next animal becomes infested, by taking these eggs into its body in food or water, contaminated with feces or urine from an infected animal.

In some species, eggs hatch on the ground and develop larvae in wet moist areas and penetrate the skin.

The intermediate stage of the lungworm gets into an earthworm and is eaten by a healthy animal.

Some flukes have an intermediate stage in which they get into snails and crayfish and are eaten by the healthy animal.

The dung beetle and some grubs are the intermediate stage of the thorny head worms.

Large roundworms and strongyloides may migrate from the intestine into the unborn pig.

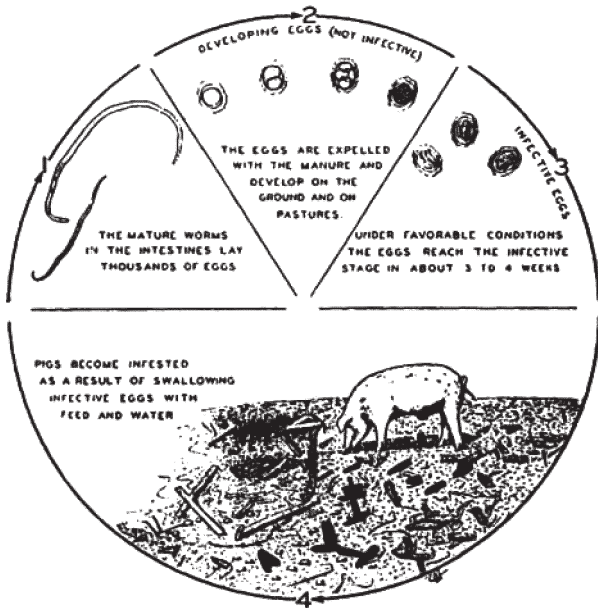

-Life history of swine ascariid.

From USDA Leaflet No. 118

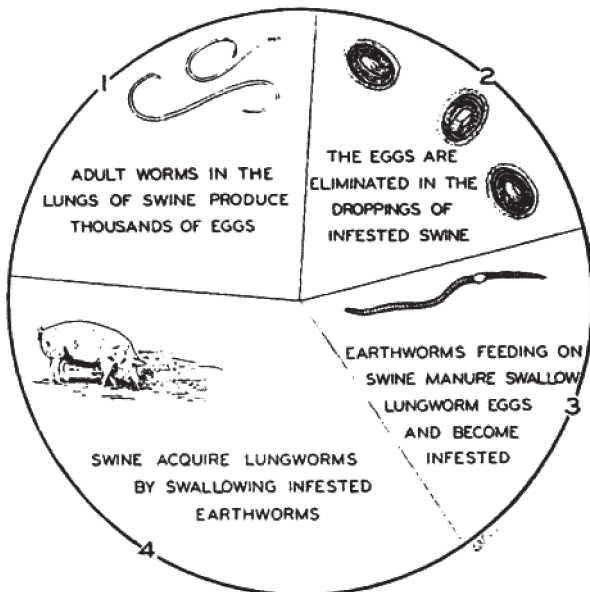

-Life history of the swine lungworm.

From USDA Farmers Bulletin 1787

Eggs of strongyloides and kidney worms may hatch in very wet soil. The immature stages penetrate the skin into the body.

D. Prevention and Control of Worms in Pigs

This is based on our knowledge of the life cycle of these worms, plus the fact, that they all pass part of their life cycle outside the pig. It is also based on our knowledge, that food and water contaminated with fecal material and urine, are the primary method of spread.

1. Good Basic Sanitation—as previously discussed in detail.
2. Pasture and Pen Rotation where pigs are often moved from one area to another allow the eggs in the soil to decrease. This is especially true when low, wet swampy areas are used for pigs.
3. Keep Newborn Pigs and Their Mothers away from other pigs, to decrease chances of becoming infested at an early age.
4. Farrow Sows and Keep Baby Pigs on Cleanest and Least Used Land. This is a major consideration. Worm cause their most serious damage to the youngest pigs and the longer we can prevent or minimize infestation the better the chance the pig has of remaining healthy.
5. As much as is practical, keep pigs away from low, wet, swampy areas, where worm eggs survive so well. This lessens the chances of eggs hatching with immature stages penetrating the skin. This is the area where earthworms, snails and crayfish, intermediate hosts of lungworm and flukes, are usually found. If low, **wet land must be used for pigs, move them often to areas not recently used.**
6. Provide fresh water in clean troughs or other containers. This lessens the chances of contamination with fecal material and urine.
7. Feed grain, ground food, garbage in clean **troughs** or other **containers.**
8. Worm Treatment Medication: This lessens the number of adult worms that can lay eggs and lessens the chances of contaminating the food and water. ***It is one of the most necessary practices in raising healthy pigs.***

9. Special Note: Prevent pigs from access to human and dog fecal waste, to lessen chances of becoming parasitized by tape worms and Trichina, that can infest people. ALWAYS COOK GARBAGE WELL BY BOILING FOR THIRTY MINUTES BEFORE FEEDING TO PIGS.

E. Medication—Worm Treatments

There are a number of medications. Some of these are effective against many species of worms (Broad Spectrum Wormers) and others only against one or two species. ***Generally the Broad Spectrum worm-ers should be used if available.*** Conditions that favor one species of worm often are satisfactory for others. Most pigs are infested with several species.

In some areas the farmer may have a choice of several medications (dewormers). In other areas, the choice may be limited. In some areas, the farmer may have to improvise by using cattle, sheep or chicken products, as a last resort, with the knowledge, that they are not ideal and may cause problems. For these reasons a large number of products are listed. We must consider that **DEWORMING IS ALMOST A NECESSITY IN RAISING HEALTHY PIGS.**

Dosages are not given, because these medications come in different forms and strengths. **ALWAYS FOLLOW LABEL DIRECTIONS ON THE CONTAINER FOR PROPER USE.** CHEMICAL NAMES ARE LISTED FIRST WITH BRAND NAME IN PARENTHESIS. These may vary in different areas of the world.

1. **BROAD SPECTRUM DEWORMERS**—effective against many species of worms. Always use, if available.

a. **Fenbendazole** (Panacur) is effective against a number of stomach, intestinal, and kidney worms.

It is effective against whipworms, if given daily for at least three days.

b. **Levamisole** (Tramisole, Levasole, Ripercol) is effective against most stomach and intestinal worms. Its effectiveness against lungworms makes it very desirable. It is also effective against the kidney worm.

Caution: Use only oral (by mouth forms)

c. **Dichlorvos** (Atgard) is effective against most stomach and intestinal worms. It is one of the few effective against whipworms, which can cause severe diarrhea.

d. **Ivermectin** (Ivomec) is an injectable product that works well against all species of internal worms. IT IS ALSO EFFECTIVE AGAINST EXTERNAL PARASITES. IT IS USED IN CATTLE AND MIGHT BE AVAILABLE IN YOUR AREA-UNDERSTAND THAT THE DOSAGE IS DIFFERENT.

e. **Doramectin** (Dectomax) is an injectable dewormer that is effective against almost all species of internal worms but not as effective against whipworms as some others. It is EFFECTIVE AGAINST EXTERNAL PARASITES. DO NOT USE THE POUR-ON FORMULA IN SWINE.

2. **OTHER COMMONLY USED PIG DEWORMERS**

a. **Piperazine** is effective against two of the most common worms, Ascaris and Oesophagostomum, the large round worm and the nodular worm. Poultry farms use this product and might help you locate it. Use only, if one of the broad spectrum dewormers listed above is not available, since it is only effective against two of the many species.

b. **Thibendazole** (TBZ, Omnizole) can be used in baby pigs as young as one week of age and in pigs with serious worm problems. Usually the mother was heavily infested with worms and not treated before farrowing. Cattle and sheep farms use this product, but we would only use it if one of the broad spectrum dewormers is not available.

c. **Pyrantel** (Banminth) is effective against Ascaris and Oesophagostomum. It is used if broad spectrum dewormers are not available.

d. **Phenothiazine** is a cattle and sheep dewormer that has been used in pigs. **It often makes pigs sick** and should not be used if others are available. It is only effective against two species of worms. **DO NOT USE IN PREGNANT SOWS. DO NOT OVERDOSE:**

e. **Trichlorfon** (Neguvon) is a feed mix product effective against ascaris and hyostrongylus. **WARNING DO NOT FEED TO PREGNANT SOWS AND BOARS. FOLLOW DIRECTIONS CLOSELY FOR MIXING IN FEED.**

NOTE—There may be other products being used satisfactorily in different areas of the world. **THE AUTHOR WOULD APPRECIATE INFORMATION ON OTHER COMMERCIAL PRODUCTS AND HOME REMEDIES BEING USED. SEE ADDRESS IN BACK OF THE BOOK.**

F. TREATMENT SCHEDULES

1. NORMAL CIRCUMSTANCES: NO MAJOR STUNTING OR DIARRHEA

a. Pregnant sows-administer deworming treatment 1-2 weeks before farrowing (birthing) **WITH A DEWORMER APPROVED FOR THIS TIME: DO NOT USE DRUGS NOT APPROVED FOR THE PREGNANT SOW.**

b. Pigs a few days after weaning—**ABSOLUTE**

If symptoms are severe and weaning is later than 5-6 weeks of age, it may be necessary to use one of the products approved for baby pigs, at around 4-5 weeks of age.

Repeat the treatment 4 weeks later

c. Boars deworm 2-4 times per year with a product approved for pregnant sows.

d. Gilts administer deworming treatment 30 days before the first breeding with a broad spectrum dewormer.

2. SEVERE STUNTING PROBLEMS SLOWED GROWTH AND DIARRHEA

a. Thibendazole in baby pigs at one week of age.

b. Broad spectrum dewormer at 4-5 weeks of age

c. Repeat the treatment after one month and again two months after the second treatment.

d. Pregnant Sows 1-2 weeks before farrowing (birthing) with an approved dewormer.

Repeat after weaning before rebreeding.

WORM TREATMENT IN HERDS WITH SEVERE PROBLEMS IS VERY COSTLY. PREVENTION AND CONTROL MEASURES ALREADY DISCUSSED SHOULD BE FOLLOWED TO REDUCE THE NEED FOR HEAVY MEDICATION, SAVE MONEY AND RESULT IN HEALTHIER PIGS.

G. DEWORMER DRUG FORMS AND NOTES ON USE OF DEWORMERS.

1. For a few pigs

DEWORMER POWDER OR CRUSHED TABLETS in a small amount of feed-follow directions.

TABLETS are difficult to administer to pigs, especially larger animals.

DRENCHES—often used but care is needed to prevent strangulation that can lead to death or pneumonia.

SKIN POUR-ON preparations usually do not work well in swine.

2. **FOR LARGER GROUPS OF PIGS**—water medication with a dewormer labeled for this route works well but animals must not be allowed to have access to any other source of drinking water.

3. **INJECTIONS** works well but experience is needed. Syringes and needles must be sterilized or disposables used. Injections work well in adult animals. They may be used in other ages.

4. **FEED MEDICATIONS**—are used but often are not available in many areas and usually not packaged for a few animals.

H. **DEWORMER DRUGS APPROVED FOR PREGNANT SOWS**

- | | |
|---------------------------|---------------------------------|
| 1. Dichlorvos (Atgard) | 4. Ivermectin (Ivomec) |
| 2. Levamisole (Tramisol) | 5. Doramectin (Dectomax) |
| 3. Fenbendazole (Panacur) | 6. Thibendazole (TBZ, Omnixole) |
- less often used

!!!CAUTION!!!DEWORMING MEDICATIONS CAN CAUSE PROBLEMS IF LABEL DIRECTIONS ARE NOT FOLLOWED CLOSELY AS TO DOSAGE, ROUTES OF ADMINISTRATION, AGE OF ANIMALS AND STATE OF PREGNANCY!!!PRODUCTS AND LABEL DIRECTIONS FOR THEIR USE MAY VARY FROM COUNTRY TO COUNTRY!!

!!!DEWORMER MEDICATIONS, AS ALL MEDICATIONS, HAVE LISTED TIMES FOR WITH-DRAWAL FROM THE ANIMAL BEFORE SLAUGHTER!!!FOLLOW THE LABEL CLOSELY!!!

1. **Flukes** are unusual flat, leaf shaped worms that parasitize many animals. Several species of lung and liver flukes infest pigs. Lung flukes cause damage similar to lung worms that leads to bronchitis, pneumonia and severe stunting. Liver flukes damage the liver and cause stunting.

Flukes in pigs are usually found where animals have access to low, wet, swampy areas. This is because intermediate stages outside the pig require crayfish or snails as part of the life cycle. Since snails and crayfish are found in low, swampy areas, the **obvious control and prevention is to limit access by pigs to those areas.**

There are **no** practical and **safe** ways **to treat** pigs infested with flukes.

J. **Worms in Pigs That May Affect Humans:**

1. **Tapeworms**—The pork tapeworm, taenia solium, affects swine in the intermediate stage, while the adult stage is in humans. The intermediate stage in swine is a small blister appearing lesion, in various organs and muscles. Humans are infested by eating raw or slightly cooked pork products. The intermediate stage develops into a full grown tapeworm, that causes health problems in humans. Segments from the adult worm pass in human feces.

Pigs become infected when they have access to human fecal waste by rooting in soil, or when their food and water are contaminated.

Control and prevention are by limiting access of pigs to human feces, by good sanitary practices by humans, and by cooking all pork well done for human consumption.

The **Hydatid Tapeworm** (echinococcus granulosus) is a tapeworm that infests pigs in the intermediate stage and dogs in the adult stage. Occasionally humans become infested by eating raw or improperly cooked pork. Control includes preventing **dogs from straying through hog pens and pastures** and preventing dogs from eating raw pork products. The practice of giving dogs **raw pork scraps at butchering** time should not be allowed.

2. **Trichina (trichinella spirallis)** is the worm parasite of pigs. It is most often thought of as causing a problem in humans. The Trichina are microscopic worms in the muscle meat of pigs. Humans become infested when they ***eat raw or improperly cooked pork. Dogs and other meat eating animals become infested by eating dead pigs or pork scraps. Control and prevention in pigs and later problems in humans is by cooking garbage and preventing pigs access to human and dog feces. Dead pigs should be buried or burned.***

Always cook all pork products well done if used by humans.

This is the worm parasite in pigs which has caused most of the reluctance to human consumption of pork. By following the few suggestions outlined previously, pork should be completely safe for humans.

V. External Parasites (insects) That Affect Pigs

A. **External parasites** of pigs include those parasites that live on the outside of the pig and usually on or in the skin. Some of these, lice and ticks, are easily seen but mange mites are microscopic. Their presence is noted by a severe skin irritation. They cause problems by severe skin irritation that may lead to skin infection, as germs enter the broken skin. They may spread germs from animal to animal, and carry a malarial type blood parasite. Ticks and lice are blood suckers, and contribute to anemia problems. All contribute to stunting and poor health.

1. **Lice** (*Hematopinus suis*) is the most often noticed insect problem of pigs. They are usually found around the head, neck and between the legs. The adults are 1/8 to 1/4 inch long, greyish-black in color and easily seen on white pigs, but less easily seen on black pigs. Pigs with lice are restless, and scratch a lot. The skin may be irritated. Affected pigs are usually unthrifty.

The adults lay eggs on the same pigs, the life cycle is repeated, as eggs hatch and immature stages grown to maturity. They may move to another pig as they lie side by side, or when a pig scratches them off on a pole or wall, and they later get on another pig.

Treatment involves use of sprays, dips, dusts or pour-on insecticidal chemicals, approved for use on pigs. Treatment should be repeated in 2-3 weeks. ***This is one of the most often required management practices in raising healthy pigs. A Table of Insecticides approved for pigs, follows at the end of this Section.***

2. **Mange** is the common name for a skin infection caused by mites of two species, **Sarcoptes** and **Demodectes**. They are too small to be seen without magnification. They burrow into the skin, most often around the head, neck and shoulders and cause a severe irritation. It is first seen as a reddening of the skin, later severe, followed by scabs. They are first seen around the ears, later over the face, neck and other parts of the body. The severe irritation and scratching caused by the mites is usually followed by skin infection, and a stunted unhealthy pig.

Mange mites live their entire life on the pig. The life cycle is repeated in the skin. They may spread to other pigs by direct contact or when scratched off on a post or wall and later get on other pigs.

Treatment is difficult because the mites are in the skin. Spraying or dipping is necessary and must be repeated in 10-15 days. ***Insecticides, that kill mange mites, and are approved for pigs, are listed at the end of this Section.***

3. **Ticks** of several species affect swine. Ticks, commonly found on cattle, sheep, dogs and wild animals may affect swine. Ticks do not spend their entire life cycle on an animal. At various stages of their life cycle, they drop off on bushes and small trees and later attach to another animal. This makes them important in the spread of diseases. They are blood suckers and cause skin irritation.

SWINE EXTERNAL PARASITE TREATMENT PRODUCTS (INSECTICIDES)

PESTICIDE	MINIMUM DAYS LAST APPLIED TO SLAUGHTER	METHOD AND RATE
-----------	--	-----------------

INSECT: NUISANCE FLIES, COCKROACHES, ETC.

cyfluthrin 0 SPRAY: Apply 8-16 ml Tempo 2/ 92.9 sq meters (1000 sq ft.) enough water for coverage but not to allow dripping for surface application or 8-16 ml Tenpo 2/ 3.9 liters (gal) water for cracked/ crevice. Application may be reapplied on 10-day intervals.

REMARKS: Do not make applications of Tempo 2 when animals are present in facility, Allow to dry before restocking. Keep out of feed and water.

permethrin
POUNCE 25 WP 0 SPRAY: Mix 170.3 g/41.6 liter (6 oz/11 gal) or 118 ml/ 11.4 liters (8 level Tbsp/ 3 gal water). Apply 3.8 liters /69.75 sq. meters (1 gal/750 sq ft) of surface.

REMARKS: Do not apply directly to animals. Do not contaminate feed or water.

INSECT: LICE, FLIES*

coumaphos 0 0.125% SPRAY: Mix 1.9 liters EC/378.5 liters CO-RAL 11.6% EC and 25 % WP WP(2qt/100gal). Apply until animal is wet.

REMARKS: Follow Label carefully.

CO-RAL 1% Dust 0 HAND DUST: Apply 28.4 g (1 oz)/animal as necessary but not more than once every 10 days. Apply 56.75 g/ 2.7 sq meters (2 oz/30 sq ft) of bedding (not more than once every 10 days).

tetrachlorvinphos 0 0.5% SPRAY: Mix 1.8 kg/189.25 liters RABON 50% WP (4 lb/50 gal) water and apply .95-1.9 liters (1 -2 qts) diluted spray per head

REMARKS: Repeat in 2 wks if necessary.

RABON 3% dust 0 HAND DUST: Apply 85.2-113.5 g (3-4 oz) dust to each animal or treat bedding with 454g dust/13.9 sq meters (1 lb/150 sq ft.)

REMARKS: Do not repeat more often than once every 14 days.

fenthion 14 BACK TREAT: Ready to use. 14.8 g/ TIGUVON 3% SOLUTION 45.4 kg (1/2 fl oz/ 100 lb) body weight.

REMARKS: May treat lactating sows to reduce lice on nursing pigs.

*Includes houseflies. other nuisance flies which are attached to or breed around pig parlors, etc. See Fly Control under Beef cattle barns, feed lots, and poultry fly control for more information.(. . . .)

INSECT: LICE, MANGE

lindane EC (6.5-20%) 30 0.05% SPRAY: Mix according to label. Wet or 25% WP animal thoroughly. Do not apply to pregnant sows.

REMARKS: Repeat treatment in 2-3 wk if necessary.

HOG OILER: 0.25% oil solution. Mix according to label instructions. Do not apply to pregnant sows.

REMARKS: Do not expose animals less than 3 mo old

fenvalerate 1 0.05% SPRAY: Mix .95 liter / 189.25 liters (1 qt / 50 gal) water or 28.37 g / 5.7 liters (1 oz / 1 1/2 gal) water. Apply up to 227 g (8 oz)/animal directly to areas of heavy infestation.

phosmet 1
PROLATE,
DEL-PHOS (11.6%)
1% DUST
0.125% SPRAY: Mix .95 liters/ 95 liters (1 qt / 25 gal) should treat 100 adult animals.
HAND DUST: 14.2-28.4 g (1/2 - 1 oz)/ animal.

REMARKS: Repeat in 14 days if needed.

INSECT: LICE, MANGE (Cont)

permethrin 5 0.025% SPRAY: Mix .95 liters 5.7% EC/ 189 liters (1 qt / 50 gal) water)

ECTIBAN 5.7% EC
Thoroughly spray entire animal with particular attention to ears and head. Treat pen area also.

ATROBAN. EXPAR 5
PERIVIECTRI 1% EC
Mix: .47 liters 11% EC/189 liters (1 pt./ 50 gal) water. Apply same as above.

REMARKS: Same as above.

ECTIBAN D 5
PERMECTRIN (0.25% dust)
HAND DUST: Apply 28.4 g (1 oz (2 1/2 tsp))/animal.

REMARKS: For lice only. Apply a second treatment in 14 days.

INSECT: MANGE

amitraz
TAKTIC
0.125% SPRAY: Mix .47 liters / 95 liters (1 pt/25 gal) water or 59 ml / 11.4 liters (2 fl oz/3 gal) water. Spray 12.5% EC animals, walls, floor with course spray.
Dip: Use same mix above to dip piglets

REMARKS: Repeat treatment in 7-10 days if need- Spray boars every 2-3 months.

ivermectin 1% 18 Subcutaneous injection 1 ml(cc)/34 kg (75 lb) body weight
(IVOMEQ injectable)

INSECT: MAGGOTS* IN WOUNDS

lindane 3% smear or 0
3% aerosol
SMEAR OR SPRAY: Apply as needed to wound. Do not apply to pregnant SOWS.

coumaphos

CO-RAL 1-5% dust 0

DUSTER CAN: Apply as needed to wound, but not more than once every 10 days.

CO-RAL 3% aerosol

SPRAY FOAM: Same as above.

chlorpyrifos PURINA 0

SPOT SPRAY: 2.5% aerosol.

WOUND INSECTICIDE

*Maggots may be secondary screwworms, black blowflies, or other flesh flies.

Neguvon (trichlorfon) Bayer 97% Soluble Powder

For lice and mange control

Use as a 0.15% Solution (15 grams per 10 liters water)

For external application (wash or spray)

::WARNING::DO NOT USE ON PREGNANT SOWS OR BOARS

DECTOMAX(doramectin) is a newer injectable product, that is effective against lice and mange, as well as, internal parasites. It is safe for baby pigs and pregnant sows.

CAUTION:::SEE NOTES ON BOTTOM OF PAGE 117 REGARDING PRE-CAUTIONS FOR SAFE USE OF THESE INSECTICIDE PRODUCTS:

4. Screwworms and other larvae that infest wounds.

There are a number of insects that are attracted to wounds in animals. These flies lay their eggs in open wounds of living animals, including castration wounds and at times will lay their eggs in the navel (umbilicus) of the newborn. The eggs hatch and larvae develop. ***The most serious of these, screwworms (Callitroga hominivorax)***, destroy tissue and cause very serious infections to develop in the wound. Other type larvae in wounds are not so serious. In any area where these wound larvae of any type are known to occur, it is a good idea to prevent them.

The following help in prevention of screwworm problems:

- a. Treat all known wounds with a fly repellent containing an insecticide; there are many sprays and lotions available, containing these products.
- b. If these are not available, use any locally available insect repellent including some home remedies such as Pine Tar or Pine Oil. Try to prevent wounds as much as possible. Prevent mange and lice which cause scratching and may start a wound. Do not use barbed wire.
- c. Treat infected wounds with insecticidal products to kill the larvae, and use antibiotics to treat the wound. In some cases, injectable antibiotics are necessary
- d. Bury or burn all dead animals.

C. Notes on Use of Insecticides in Pigs

1. **Insecticides are potentially dangerous drugs, much more so than other drugs used in animals. Always follow directions closely, especially mixing and dilution.**

2. Be especially careful when using insecticides ***on sows*** just ***prior to farrowing***, and while ***nursing*** their baby pigs. Pigs may ingest insecticide as they nurse. Serious problems could result. Use with care ***on baby pigs***. Lice are usually the only insect problem before 5 weeks of age. Mild dusts such as 4-5% Malathion are safest. Use others ***only if label contains directions for baby pigs***.

3. **CAUTION: Follow Label Directions Very Closely for Withdrawal Times Prior to Slaughter.**

CAUTION: DO NOT USE ANY PRODUCT NOT LABELED AND APPROVED FOR USE IN SWINE AND FOR THE AGE AND STAGE OF PREGNANCY OR LACTATION:

SPECIAL CAUTION::These products can be very dangerous to humans if directions are not followed closely. Some may require the use of face masks, goggles, rubber gloves, etc., to prevent harm to humans, using the products.

A practical and inexpensive method that can help prevent and control insect problems in livestock is the back rubber. Animal with lice, ticks or mange like to scratch and this can attract them. Heavy Diesel fuel or new motor oil are even better with added approved insecticide, (following label directions) when used to saturate the burlap. Following are drawings of a tree wrapped with burlap and a tree used for support of a swag rubber.

Posts -can be substituted for trees, however shade from the tree will help attract animals to the tree rubber.

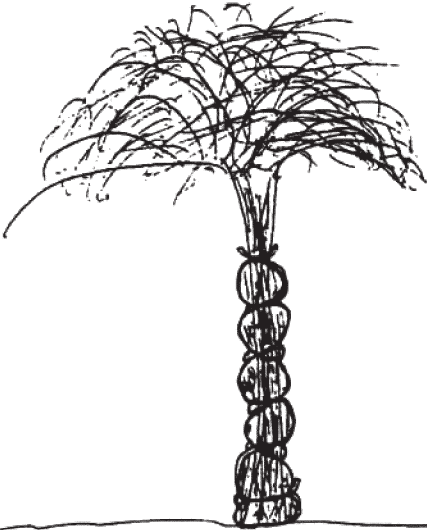

DEC

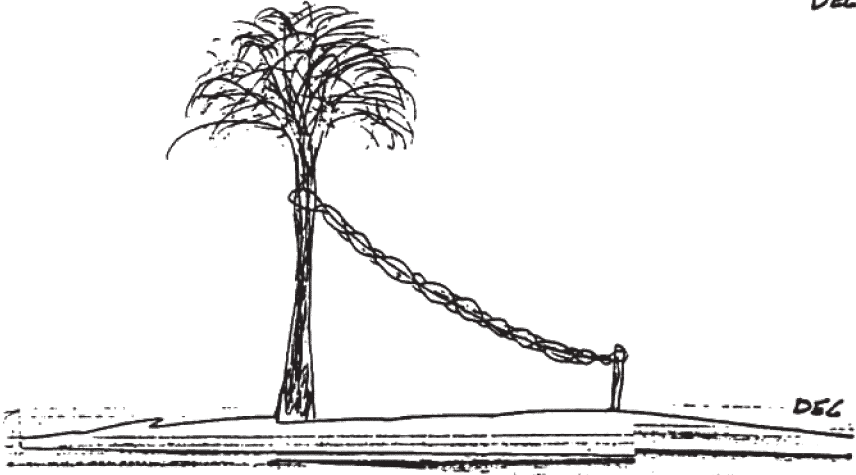

DEC

V. Diseases of Swine.

It is not within the scope of this booklet, nor would it serve a real purpose, to go into great detail on all the diseases of swine. Earlier parts of this section on Health Problems which describe more common problems, are more useful.

Diagnosis of major diseases is difficult even for experienced veterinarians with laboratory assistance. Treatment is expensive, drugs are often hard to find, and results are poor, with resulting death losses, and stunting in survivors.

Prevention of Health Problems through previously mentioned guidelines should be our goal.

A. **Hog Cholera** (Swine Fever) is a highly contagious and highly fatal disease of pigs caused by a virus. It is generally considered the worst disease of swine in the world. Though eradicated in some countries, it is still a very serious problem in many areas.

Affected animals are first noticed by their lack of appetite which is caused by the high fever. Soon after this, they become weak and depressed. Many develop diarrhea. Death follows in a high percentage of affected animals. Recovered animals are often weak and unthrifty.

This disease may spread rapidly through an area where many farms have pigs. Keeping animals closely confined to prevent contact with other pigs is a good idea. Keep pigs away from streams because the virus may travel from farms with sick pigs.

If the disease is known to be in an area and cases are frequent, it would be advisable to vaccinate against it.

If it has not been diagnosed, but sickness that is suspicious of it does occur, try to get help in diagnosing it. In most countries, government or university veterinarians are available for help in disease outbreaks. They should be advised of suspicious cases in an area.

B. **African Swine Fever** is a very serious disease of pigs which, in many respects, is similar to hog cholera. Laboratory tests are needed to differentiate between the two diseases.

Until the past 10-15 years, this disease only occurred in the continent of Africa. It is now widespread with outbreaks in parts of Europe, South America and the Caribbean.

Other information on Hog Cholera applies here. Suspicious cases should be reported to government veterinary authorities.

C. **Foot and Mouth Disease** (Aftosa) is a very serious disease in pigs as well as other livestock. It is also very contagious and rapidly spreads through an area. The fact that other livestock are involved, allows it to spread through an area more easily.

The disease is usually not hard to diagnose. The combination of vesicles (hard thick blisters) inside and outside the mouth, snout, feet and udders, is very likely to attract attention. These lesions later become red and raw as vesicles rupture.

Animals become very lame and are reluctant to eat because of the sore mouth.

Death losses are usually not great, but the stunting and general poor health in survivors causes great economic loss to the farmer.

Vaccines are available and should be used if possible in an area with frequent outbreaks.

Suspicious cases should be reported to veterinary authorities.

D. **Erysipelas**—is a bacterial disease of pigs, which occur worldwide. It is considered one of the major diseases of swine, but it is not as contagious in its spread through an area, as the previous viral diseases.

It occurs in two forms. One is a highly fatal condition, which results in deaths in 24-72 hours, in affected pigs. Pigs develop a very high fever, sore swollen joints, are reluctant to move, but usually remain alert until near death.

The other form manifests itself by a chronic arthritis or raised reddish diamond shaped areas of skin. Stunting is the problem associated with this form of Erysipelas.

Vaccines are available and should be used on farms with previous problems. It often recurs on the same farm.

Like Brucellosis and Leptospirosis this disease **can spread to humans**, mainly by contamination of cuts and sores on the hands and arms. Care should be used when handling sick animals; rubber glove or at least not allow persons with cuts and sores to assist. Wash hands afterward.

E. **Brucellosis** (Bangs Disease) (Infectious Abortion) is a major reproductive disease of pigs. It occurs worldwide. It is caused by bacteria that affects the reproductive organs of adult males and females.

It causes poor conception, early and late abortions, weak and still-born pigs, and small litters. Animals are not noticeably sick. It is usually brought into a herd by infected breeding stock, who in turn, infect others. An infected male may spread it to sows, and from an infected sow to others. Newly purchased animals should be blood tested, prior to purchase.

Sharing boars may spread the disease.

It spreads within a herd when sows have an abortion and at farrowing time.

The causative agent of swine brucellosis is **brucella suis**, this is a bacteria, **that cause the human disease, undulant fever. Special care should be exercised when assisting at farrowing time, breeding times, and during abortions. The organism is often found in discharges and blood, from the reproductive organs, of infected animals.**

If possible, rubber gloves and face masks should be worn, when assisting at farrowing, breeding or after abortions and at slaughter. At the least, no one with cuts on the hands should assist at these times. Always wash hands and face after assisting.

F. **Leptospirosis**—is another reproductive disease caused by bacteria. It is worldwide. It causes a wide range of reproductive problems similar to Brucellosis. Animals are rarely visibly sick.

Strains of this bacteria are found in other livestock, wild animals, dogs and rats. All of these may cause problems in pigs. This makes it difficult to control. **It can infect humans. Use caution when assisting in difficult farrowing.** See Notes earlier in "Assisting in Farrowing" and at end of discussion on Brucellosis on preceding page.

The organism is found in the kidney and passes from the body in the urine. It may spread to other animals and humans, as urine contaminates food and drinking water. This is especially true of animals drinking from ponds or small streams. As with Brucellosis, blood tests are available. There are very effective vaccines available to prevent this disease.

G. **Pox (Pig Pox)** is a disease of pigs found worldwide. It is caused by a virus. It is noticed as clean blisters on the skin, most often between the legs and under the abdomen. Blisters turn into dark raised areas that disappear within a week to 10 days. The condition is most often seen in pigs under three months old.

Deaths are rare. However, the virus does lower resistance. Pneumonia and diarrhea may follow.

H. **Parvovirus** is a reproductive disease of pigs found worldwide. It causes a variety of reproductive problems including abortions, stillborn pigs and mummified fetuses. It is much more a problem in first litter gilts, and much less a problem in older sows.

There is no treatment. However, there are effective vaccines available. Direct contact between gilts and older sows for a period of 30-45 days prior to the first breeding of gilts, results in exposure to organisms carried by the sows. This often results in some immunity to parvovirus. This practice is effective against other diseases, especially those of the newborn, by way of antibodies through the colostrum (first milk).

I. PRRS (Porcine Reproductive Respiratory Syndrome)

Porcine Reproductive Respiratory Syndrome is caused by an arterivirus (RNA virus) that is transmitted by contact with such body secretions as saliva, nasal mucus, mammary fluids, feces and urine from infected, shedding swine. After infection, the virus persists in lymphoid tissue, making it very difficult to eliminate from herds. Although PRRS virus generally does not survive for long periods of time in the environment, it may survive in chlorinated water for about a week. It is easily transmitted through contaminated water. It is also transmitted through the semen. Transmission by air over long distances is not considered important.

PRRS virus, as the name suggests, causes reproductive and respiratory disease. Typically, reproductive losses are in the last trimester of pregnancy. An affected female usually farrows 4 to 5 days prematurely. The pigs are alive but too immature to survive. Some or all of the pigs may be stillborn. Normal pigs in the same farrowing area as sows with affected litters, may develop PRRS virus-induced pneumonia, with a high death loss resulting. Females in other stages of pregnancy may abort and deaths may occur in sows and boars. Outbreaks in large swine herds may last for 3 to 4 months.

The PRRS virus can cause pneumonia in swine of any age. Younger pigs may be affected more severely. Because the lungs' natural defenses are suppressed after PRRS infection, secondary pneumonia, from a wide array of bacteria, or viruses, is usual. Treatment with antibiotics such as penicillin, tylosin, tetracycline, or ceftiofur may be temporarily effective, with many affected swine relapsing and becoming chronic poor-doers, or dying. Extra-label antibiotic such as NuFlor (1cc/30 lbs BW every 48 hours for 2-4 injections; withdrawal time 45 days) may be effective in these chronic cases.

Basic strategies to deal with PRRS are: Try to keep it out of a PRRS virus-negative herd by 60 day isolation and testing of new herd introductions. Develop herd immunity to the PRRS virus type(s) in the herd and try to prevent introduction of other PRRS virus variants through isolation and testing. Autogenous killed vaccine, commercially available killed vaccine (PRRomiSe by Bayer - approved for vaccination of pregnant swine) and modified-live vaccines (RespPRRS/Repro, BI NOBL and Prime Pac PRRS, Schering Plough - both approved for prebreeding vaccination of females and pigs at or after 3 weeks-of-age) are available to enhance immunity to PRRS virus. For infected herds, an important practice is purchasing or bringing in new, PRRS-negative (by ELISA test, preferably 2 tests, 30-60 days apart) breeding gilts as young as the nursery age to allow adequate time for protective immunity development after isolation and PRRS virus exposure (eg, vaccination). In addition to the ELISA or other antibody tests, a PCR test is available to sample boar semen (eg, AI studs) to monitor for virus shedding.

J. **Pseudorabies (Aujeszky disease)** is a viral disease causing high death losses in baby pigs with encephalitis (brain inflammation), occasional reproductive problems, and at times, an influenza type condition in grower-finisher pigs.

It was not thought to be a serious problem in pigs until around the late 1960s. It has become a major problem in high density swine areas with large confinement units primarily in Europe and the USA. It has been reported in other areas of the world.

There is no treatment but vaccines are available and are much used in areas with the disease. Prevention is primarily that of purchasing animals from healthy herds and testing prior to purchase.

J. **Note:** There are many other diseases of swine, especially chronic enteritis-diarrhea type diseases, and respiratory pneumonia type diseases of varying ages. There are some which cause high death loss, and others that mainly cause stunting (slowed growth), and poor feed efficiency.

They vary somewhat, in different areas of the world.

These diseases can, to a great extent, be prevented or their impact lessened. If we understand and follow the information outlined in Sections VI and VII. Those sections discuss disease and parasite prevention methods and management practices. These are within the abilities of most small farmers, and should be used much more.

Space does not permit a description of each of them. The author and Christian Veterinary Missions, the publishers of this book will be happy to assist our readers with further information if requested. (SEE THE SECTION ON CONSULTING BY MAIL IN THE BACK OF THIS BOOK.)

Section VIII

A Basic Confinement System

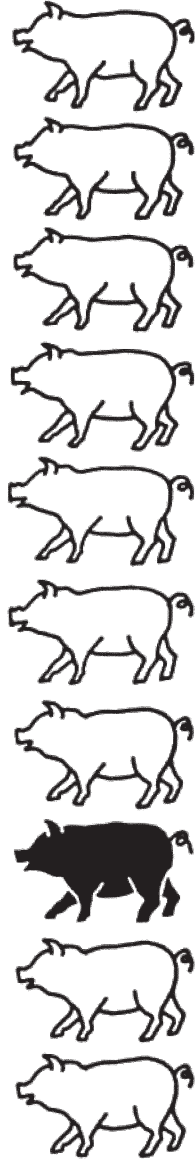

INTRODUCTION

A Basic Confinement System:

In revising this book, we felt that a chapter on a confinement system, by which healthy pigs could be produced, would be of help to those in some areas.

The system described in this chapter was developed over the past several years and has been successful. Dr's Maureen Birmingham and Rod Frank have worked extensively with a number of farms using this system. They have very graciously provided the information and drawings on which this chapter is based. We are deeply indebted to them for their fine art work.

In order to continue the general outline of the book, we will discuss environmental considerations, buildings and equipment, and management specifically related to this system. More general information on nutrition and herd health, which they supplied, that applies to both nonconfinement and confinement systems is included in earlier chapters on those subjects. This was done in order that the reader not have to do an excessive amount of reading to understand the system.

It must be understood, that in order for the system to work, the major points must be closely followed. The authors arrived at their recommendations only after much experience and many changes from their earlier attempts. That is not to say, that some local adaptation, might not be necessary or practical. However, in the earlier stages, it would be a good idea to follow their recommendations as closely as possible. Then, after one has gained some experience, they would be better able to make changes.

While not absolutely necessary, it would be highly recommended that someone involved in the operation; owner, manager, advisor, etc. have had some experience with confinement swine production. Otherwise, it should be done on a very small scale at first. Then if results are good with the small operation, expansion could follow. In some cases, it would seem a possible change for one who has been successful over a period of years in non-confinement, and who wants to expand in size but, for many reasons feels that confinement is something he wants or needs to do.

A major reason for raising pigs in confinement is the lack of land for pasturing animals or the land is too poorly drained to grow healthy pigs. While this chapter is reasonably complete, except for herd health and nutrition, it is highly recommended that one who is considering a system of this type, or one who advises others, would read the entire book to better understand pig production generally.

Special Consideration in Confinement Production of Pigs:

A. **Environmental:** Pigs by nature have a highly developed sense of adapting to weather changes and extremes of nature if left to their own devices. However in confinement we, to a great degree, interfere with these natural instincts to take care of themselves. In confinement we have to provide relief from those extremes of weather. Sows with baby pigs have a great mothering ability if left where they can use their instincts. In confinement we have to provide relief from weather extremes and changes or provide pigs with means to do that.

B. **Sanitation:** Cleanliness and waste removal: Pigs by nature tend to spread out (disperse) and do not often in nature stay in an area with very much filth, preferring to live in a clean area. Sows will, if possible, go off to themselves where no other pigs have been to make their beds and farrow. All of these habits and instincts favor their staying healthy as they do not stay where there are many germs and worm eggs. Sick animals tend to go off to themselves, another way in nature that animals are protected from sickness and disease. If we do not provide good sanitary conditions for animals, they will not remain healthy very long.

C. **Nutrition:** Pigs by nature can easily take care of themselves. They root in the soil for grubs, roots, eat nuts and acorns; and consume soil which contain minerals. They regularly consume green plants which contain vitamins. They will, if available, eat small wild rodents and other animals including snakes and birds, all of which contain much protein. Animals in confinement do not have access to those sources of nutrients. This makes our nutritional considerations (diet) ***more critical***, as pigs in confinement cannot balance off the ration you provide them, with foods which they can find themselves. Baby pigs born in confinement with floors do not have access to soil, which contains iron necessary to make blood. They soon become ill with anemia (lack of blood) and often die, if another source of iron is not provided. This is well covered later in this chapter.

Because of the above considerations, we have to provide ways to alleviate or prevent those problems. They have to be well understood by those taking care of the pigs. These are covered in the remainder of this chapter.

Facilities-Buildings and Equipment

Location of the confinement unit—there are several important considerations in choosing-the location of the unit:

1. If possible locate the buildings where there is good natural drainage, such as the side of a hill, or at least some slope to the land.
- a. If there is no natural drainage around the buildings, ditches or some form of artificial drainage may be necessary.

- b. It is very important to have a dependable source of safe water-, for drinking water and cleaning purposes.
2. Well-built farrowing houses have a steep roof and a good slope to the floor. A good rule of thumb is a 2.5 cm (one inch) drop for each 30 cm (one foot) of floor length. It is important that the cement floor is not slippery to avoid injury to the sow. In addition, the floor should have no dips, cracks or holes, where microbes and parasite eggs can hide. Tin roofs are very hot, although less likely to leak than thatched roofs. Some farmers use both; thatched roof under the tin, which makes the tin less hot but makes the roof more leak-proof.
3. Walls:
 - a) Cement: Although block walls are strong, they are hot because they don't allow for enough ventilation, even with holes in the sides. In addition, they are difficult to clean well.
 - b) Wood: Wood can work well but it requires constant maintenance. The wood must be hardwood or the sow will destroy it in no time. Make sure the wood is attached to the inside of the vertical poles. In wood sided farrowing houses, the sows and the piglets escape more easily.
 - c) Chain-link fence: This can work well if the bottom of the fence is cemented to the floor. The metal fencing is heavy enough. The top should be reinforced with wood or iron. Cost is a factor.
 - d) Iron: This material works best because; it can be cleaned well, allows for good ventilation, is secure and strong enough to prevent pigs escaping. The iron should be no smaller than .94 cm (3/8 inch) in diameter. To keep baby pigs from escaping .625 cm (1/4 inch) iron can be welded around the bottom, to make spaces smaller.

4. **Feeders and waterers** should be tall and narrow to discourage pigs from standing or bathing in them (see diagram for specifications). Placing the manger at the top of the pen and the waters at the bottom of the pen seems to decrease feed wastage and keep the pen cleaner, because the piglets tend to mess more often at the bottom of the pen, where it is wet. Feeders must be heavy enough so the sow cannot push them around, tip them or destroy them. Cement feeders that are moveable are preferred, because when the pen is converted to a maternity pen, the waterer must be kept at the top of the pen. Other types of feeders and waterers have been tried. Sows either destroy or tip barrels that are cut in half, transversely. Barrels cut longitudinally have been used successfully for small pigs, except they tend to climb into them. Tires, with holes cut into them just large enough for a pig's snout, work well as waterers for smaller pigs. They are hard to clean and they take up a lot of space in the pen.

5. if there is too much afternoon or morning sun entering the piggery, straw mats or feed sacks can be hung in such a way as to block the sun but still allow **ventilation**. Hang the mat or sack high so that air can enter at the level of the pigs.

6. **Pen size** varies but in general should be no smaller than 2.1 m (7 feet) by 2.4 m (8 feet) to allow for feeder space in front of the sow. When the pen is converted into a maternity pen, pens smaller than this are difficult to keep clean, for a sow and a large litter.

7. Three-types of maternity pen designs are shown (see diagrams and pictures). More piglets seem to be weaned using system one.

8. **Fencing**—In most confinement operations, some of the animals will be in pens on the ground or in pastures. Fencing for these pens and pastures is described in the earlier Section on Buildings and Equipment in the front of the book.

WASTE MANAGEMENT

Waste management is an **absolute necessity**, if we are to raise healthy pigs in confinement. It must be done regularly and be done well. 1. Cement canals are built at the bottom of the piggery. The canals are usually about 30 cm (one foot) deep and about 20 cm (8 inches) wide (a shovel width). In small piggeries, the waste is removed **daily** and piled close by for later use as fertilizer or it is taken **immediately** to be used as fertilizer on gardens. In the tropics, manure composts quickly. Thus, the latter method is preferable, as it avoids buildup of flies.

2. Other piggeries dig deep holes to hold the manure. When it is full, another hole is dug. This procedure is discouraged because space limitations will ultimately result. This practice is a waste of a good resource (fertilizer). In addition, these deep holes that are left open may be a hazard for the unaware to fall into them.

3. If pig waste is used for fertilizer; try to mix the pig waste (fecal material) into the soil before crops are planted. Do not place it over growing plants used for **human food** as it spreads germs and worm eggs.

4. Another possibility, is to use the waste water for irrigation of food crops for pigs. The wash water should not be put over crops used for human consumption, as it may spread germs and worm eggs.

Rami is a fiber Plant presently being grown in some areas as a protein source for pigs. It can be grown near the piggery, using **wash water** from the piggery to water it, because it does require water, and manure from the piggery to fertilize it. Under ideal conditions, the leaves and stems can be harvested 3 months after planting it (before it flowers). It can be harvested every 30-35 days thereafter, if it receives enough water.

Rami contains approximately 20% protein and it is a good source of vitamin A as well. It is fed fresh but it can be ensiled or dried. It can be used at a level of up to 40% of the diet.

5. The manure has been dried in bricks at some piggeries for ease of handling and transporting.

HEALTH AND MANAGEMENT PRACTICES

1. Some confinement systems use natural vaccination methods to protect (immunize) against organisms that cause abortion, such as parvovirus, enteroviruses, and other germs. Gilts, before their first breeding, are fed manure (fecal waste) from boars and older sows. One method is to mix about 60 ml (1/2 cup) of manure in 1.9 L (1/2 gallon) of water and mix this in the gilts' feed once daily for three days, about 3-4 weeks before breeding. Some do this routinely. There might be some circumstances where this would not be advisable, because of the danger of spreading unwanted germs. This would be the case where there was, other disease in the herd. There are commercial vaccines available for many of the germs, which cause abortion.

Leptospirosis described in the section on diseases is a kidney disease which causes reproductive problems. There are commercial vaccines available for it. In most herds, it should be used.

2. Gilts: Breed when they reach 8 months, 220 lbs., and on their third heat. If gilts are bred too small or too early, there may be problems with small litters.

3. Gilts and sows are bred, while in standing heat, every 12 hours, early in the morning and in the **evening during the cooler part of the day**. This helps prevent **overheating** and its associated problems (e.g. temporary sterility of the boars). **It is very important that gilts be trained to lead by a rope, before breeding, so that there is no added stress caused by walking the sow to the boar, when she is ready to breed.**

4. Gilts and sows must be kept in good physical condition during pregnancy—**not too fat nor too thin, to avoid problems** during and after farrowing. **Ideally one should be able to feel the backbone but not see it.** If the backbone is protruding, the sow is too thin. **If one cannot even feel the backbone** the sow is too fat.

5. Some farmers keep their **sows** on cement floors all the time. Others keep them on dirt throughout gestation and in cement-floored pens during lactation. This latter system works well, provided the sows are dewormed regularly. It helps preserve their legs and feet, allows more exercise, (if loose in a pen) and is therefore less stressful.

6. Some recommend **young pigs** be kept on cement floors because there is an increased incidence and severity of mange, parasitism and general unthriftiness, in young pigs raised on dirt.

7. **To relieve water stress**, some farmers fill pits with water and allow only the gestating pigs to wallow. This practice is somewhat controversial because the mud is a source of germs and worm eggs. However, they may be necessary to prevent the heat stress. If they are very shallow, 10-15 CM (4-6 inches) deep, and regularly alternated in order for them to dry out, they can be used satisfactorily. Sows must be kept on a good deworming program. Lactating sows with nursing pigs should not use these wallow holes.

8. it is important to make the sows and gilts **gentle**, to decrease the stress of confinement and the stress of increased human contact, when the sows/gilts are confined in maternity pens. Otherwise, they are more likely to break out of the maternity pens. All this stress may increase **milking** problems at farrowing. In general, "increased tranquility = increased piglets weaned".

9. Many farmers use a natural vaccination method against E.coli and other organisms that are present in most herds. They often cause diarrhea (scours) in baby pigs. The gestating pigs are fed cut-up intestines from piglets that died from diarrhea or they are fed manure from lactating sows (since lactating sows are more stressed, and thus are more likely the shedders). This is done twice (preferably 3 and 6 weeks) before farrowing. This practice is not without **its risks**. These natural vaccines can be used in places where there is no refrigeration or availability of vaccine, and where baby pig diarrhea is a particular problem. It is easy for a farmer to do. Note: We don't recommend this practice if there is a known problem with clostridia or coccidia on the farm.

(See Later Notes on Coccidia in This Section).

Some do this routinely. Others do it only if there are problems. **With the best sanitation- waste removal possible this may not be necessary.** There are commercial vaccines available for these baby pig diarrheas.

10. 5-10 days before farrowing the maternity pens are washed and rinsed with clorox at a **1:10 water** solution. Keep in mind that clorox is not effective in the presence of organic matter. The sows are bathed with soap and water, wormed and placed in the maternity pens. Sows that are not gentle or are easily stressed, are placed in the maternity pens sooner than this. Since exercise is suddenly restricted, constipation can result. This can increase the possibility of **milking problems**. Local greens and fruits such as papaya or 7.5-15 ml (one or 2 tablespoons) of epsom salts (magnesium sulfate) per day in the feed can help keep the manure soft. It is advantageous to give the sows exercise daily.

Clorox is a brand name for household chlorine, laundry bleach. It might be found under other names in different areas. Epsom salts is also known as Magnesium sulfate.

11. Farrowing should be attended and at farrowing, farmers should do 5 things:

A) **Respiration**: Cleaning the piglet's mouth and nose of fluids, and rubbing the piglet dry, can help stimulate breathing.

B) **Needle Teeth**: Cut needle teeth but do not cut the gums. Often farmers will disinfect the site where the teeth are cut. Caution must be exercised as to what disinfectant is used and at what strength. Whole litters have been lost, with the use of a strong solution of roccal for this purpose. Most farmers use nail clippers because they are relatively cheap and available. When the needle teeth are not cut, there is an increased incidence of greasy pig disease, mammary abscesses and mastitis.

C) **The umbilical cord** is cut with a disinfected knife. The cord is then disinfected. If the cut end of the navel cord bleeds more than a few minutes, it should be tied off with a piece of disinfected thread or fishing line.

D) **Colostrum** (first milk) is extremely important, because the newborn pig's immunity (protection against disease) comes from antibodies in this first milk. Everything possible must be done to insure that the newborn pig nurses regularly the first several days. The newborn pig gets energy in the form of lactose (milk sugar) from colostrum. Without consuming adequate amounts of colostrum, the newborn has a poor chance of survival.

E) **Clean, warm and dry**: Piglets cannot regulate their body temperature well. They must be kept clean, warm and dry in order to survive.

12. Newborn piglets should be kept at 27-32 C (80-90F). They should be insulated from the cold floor! Farmers often use straw or grass to make a nest in the corner of the pen. Baskets with straw inside have worked well. Since they are usually cheap, they can be discarded between litters. To teach the piglets that this is their home, the baskets are kept upright with the litter inside them for periods of time, during the first two days. After that, the baskets are left on their sides, so that the piglets can enter and exit on their own. In a similar fashion, farmers have used wooden boxes or nailed planks across one corner of the pen and placed straw in the enclosed area. **One disadvantage** of wooden boxes is that they are difficult to disinfect. For this system to work, the caretakers must be conscientious. During those first 2 days, when the baskets or box are kept upright, or the piglets are confined in a corner, the piglets must be removed every hour to nurse otherwise hypoglycemia (low blood sugar) quickly ensues

and sow milk production decreases. For supplemental heat, charcoal heaters and warmed rocks have been used, with limited success. Some pig farmers, living in areas where it is quite cool, hang a kerosene lamp as a hover. Keep in mind there are fire hazards associated with these procedures, especially, if the roof is made of straw. If the piglets have a nest of straw that is clean (i.e. changed frequently) and dry, they do quite well. Electric lamps work well as a source of heat.

13. **Overheated sows** are often a very serious problem in confinement. Shade and good ventilation are a must, when sows are farrowing and nursing baby pigs. They can be bathed in water. Try not to get the floor wet, which can cause problems for the baby pigs. Piggeries made of block, even with some holes in the walls, are too hot due to lack of ventilation. They are difficult to clean.

14. **Baby Pig Anemia**—(lack of blood) must be prevented if sows farrow in **flooded pens**; otherwise the newborn pigs will die or become very unhealthy. Pigs normally get iron, that is necessary for blood formation, from eating dirt-soil the first few days of life. In confinement, a source of iron must be provided. If iron is not available, or the farmer is reluctant to give injections, clean dirt (void of pig manure) can be used. Iron in dirt is usually of a form, that is nutritionally available to the pig. The yellow and reddish colored, heavier clay type soils usually have more iron in them. The lighter sandy type soils **usually** have less iron in them. Solutions of ferrous sulfate can be used, if available. Mix one teaspoon of ferrous sulfate (30%) in 0.95 L (one quart) of water and sprinkle "clean" sod (a clump of dirt with grass growing on it), keep this sod in the pen out of reach of the sow. If no other source of iron is available, tomato juice can be used. It has 4000mg/kg of iron on a DM basis. Give the baby pig one tbs. by mouth twice weekly for the first 2 weeks of life, starting on the first or second day of life. There are commercially available injectable and oral products that contain iron in a form prepared specifically for baby pigs. However, they are often not available. **Also see notes on Baby Pig Anemia in the earlier section on Reproduction.**

15. By the tenth day of age, piglets should have been introduced to creep feed. The quality of the creep feed is very important. Five to ten percent powdered milk, mixed in the feed, encourages consumption by the baby pigs. If cow milk or goat milk is a surplus situation or very cheap, it can be used. It is a way to introduce young pigs to solid food. Mix bread or creep feed in milk in gradually increasing amounts until pigs are eating well. Do not let the food and milk spoil; clean food containers daily. **In the section on Nutrition, there are examples of several creep feed formulas.**

16. By two weeks of age, baby pigs should have been castrated. See earlier notes on castration procedures in the section on Baby Pig Management.

17. Baby pigs with bacterial scours are treated with oral electrolytes and oral or injectable antibiotic (depending on the preference, availability and abilities of the farmer). The contents of the avocado seed has been helpful in treating baby pig scours. It has a bad taste, and must be mixed with something else to encourage consumption. Goave has a constipating effect. When water quality is not satisfactory, Tincture of Iodine may be added to drinking water, at the rate of 5 ml (one teaspoon to 19 L (5 gallons) or 45 ml (3 tablespoons) to 190 L (50 gallon) barrel

18. Piglets that are eating creep feed well, have reached 15 lbs of body weight, can be weaned. This usually occurs around 5-8 weeks of age, if all goes well.

19. Warm temperatures are very favorable for the survival of *coccidia* (one celled parasites that cause scours in baby pigs). Many farmers have sows farrow on solid floors. If they do not do a good job of waste removal, this means fecal waste-manure is often on the floor, where the baby pigs are. The fecal material may contain coccidia, as well as the other organisms, that cause scours. It is important to empty the maternity pens, clean and disinfect them thoroughly and leave them empty for at least 3 days. Coccidia are very resistant to most environmental factors. Ammonia 0.240 L (8 ounce) per 3.8 L (one gallon) or Lysol disinfectant. .12 L (4 ounce) per 3.8 L (one gallon) or 1:10 water solution of Clorox or other comparable household chlorine, laundry bleach is effective, if all organic matter (trash and waste) is removed beforehand. Flaming and steaming of the pens is the most effective measure but not usually practical under most small farm conditions.

Note: The above control measures for coccidia would be very good for any disease problem in confinement, including baby pig scours.

20. The quality of the post-weaning ration is very important. At weaning gradually changeover the feed from the creep feed to the post weaning ration. Medicated feed or water during this stressful time (sulfa, apralan, tetracycline, ASP 250, etc) can help control postweaning scours and improve gains. Sulfa is especially helpful, if coccidia is a problem.

21. After weaning the baby pigs, adequate feeder space is important. There should be enough feeder space so that all the pigs can eat at the same time.

22. Weaned pigs need a clean, warm, dry place to sleep. Sanitation is a must in the weaner pens.

In addition, put some straw in to insulate them against the cold cement floor.

Nutrition in Confinement

The most important thing to consider in confinement, is the fact, that the animal in confinement cannot use its natural instincts, to balance its ration. For that reason, we must supply the animal in confinement, a balanced ration. Probably the most neglected nutrient in confinement is vitamins. They are easily supplied by giving the animals some fresh forage-greens daily, or as often as possible. Minerals have to be supplied, either in the feed or free choice. This has to be done because animals in confinement do not have access to soil, where they often get their minerals. ***There are Sample Ration Formulas of complete feeds for all age animals in the section on Nutrition. It would be good for a person planning a confinement operation to read thoroughly the section on Nutrition.***

Always remember, a constant supply of ***fresh water*** is very important. Without a supply of fresh drinking water, the animals do not eat and grow as well; are not able to handle heat stress as well; and have other problems. ***Also see notes on Water in the section on Nutrition.***

Parasite Prevention and Control in Confinement

Under ideal confinement conditions, parasites may not be as serious a problem as in pigs raised on the ground. We should still consider parasites to be a major problem. Failure to have adequate internal and external parasite control and prevention programs, can lead to serious health and stunting problems. For best results, we should follow the information in the section on Health that covers parasite control and prevention.

Drawings of buildings and equipment follow this section on Confinement.

(Material for this section on confinement was adapted from material supplied by Dr. Rod Frank and Dr. Maureen Birmingham).

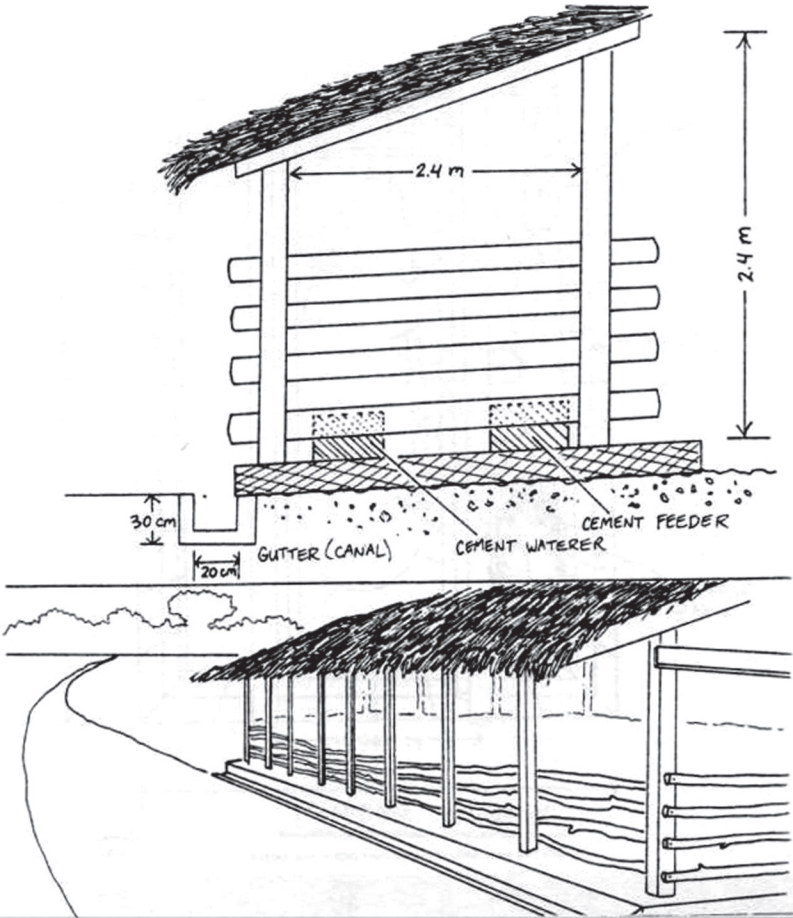

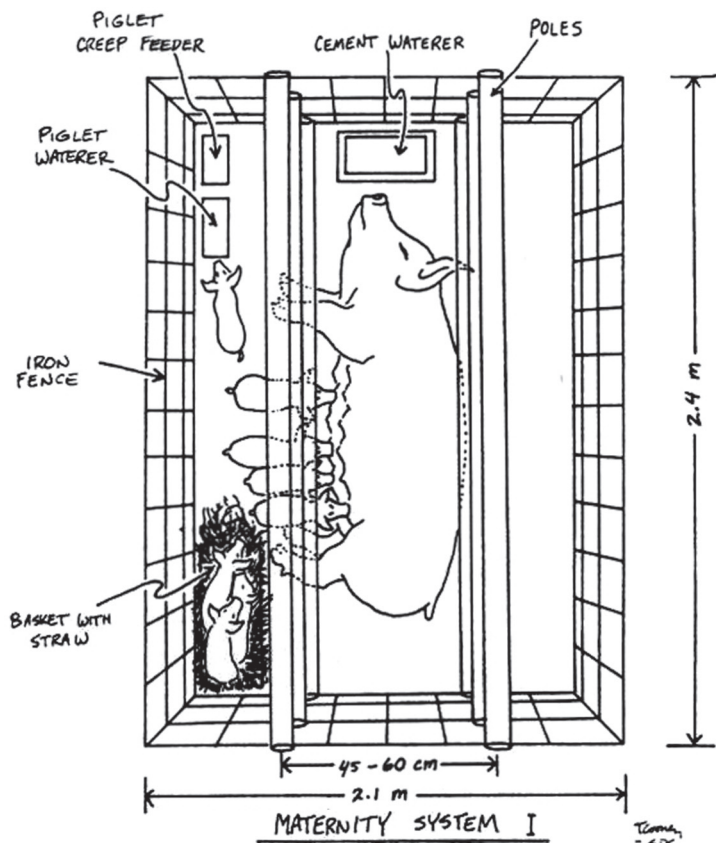

Outside pen walls made of iron so baby pigs cannot escape



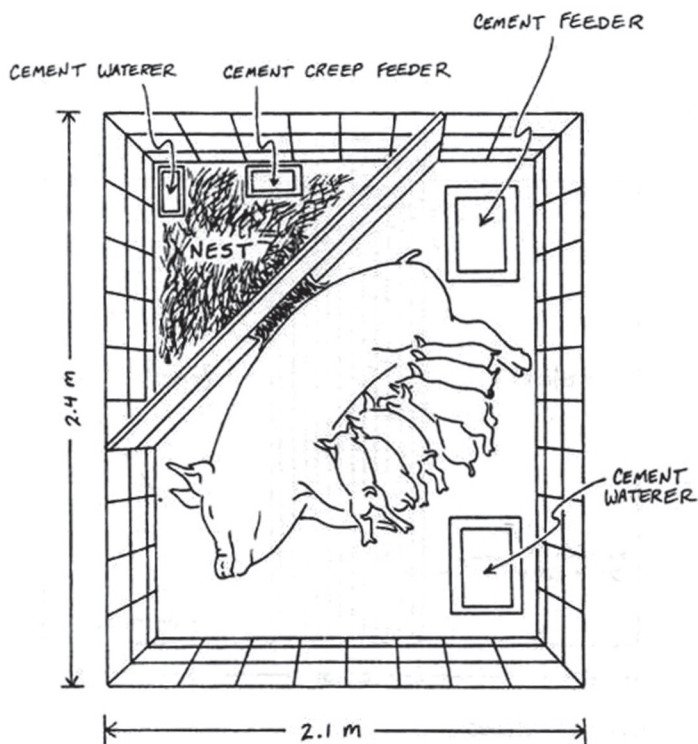

MATERNITY PEN SYSTEM 2

T. 2006 - 906

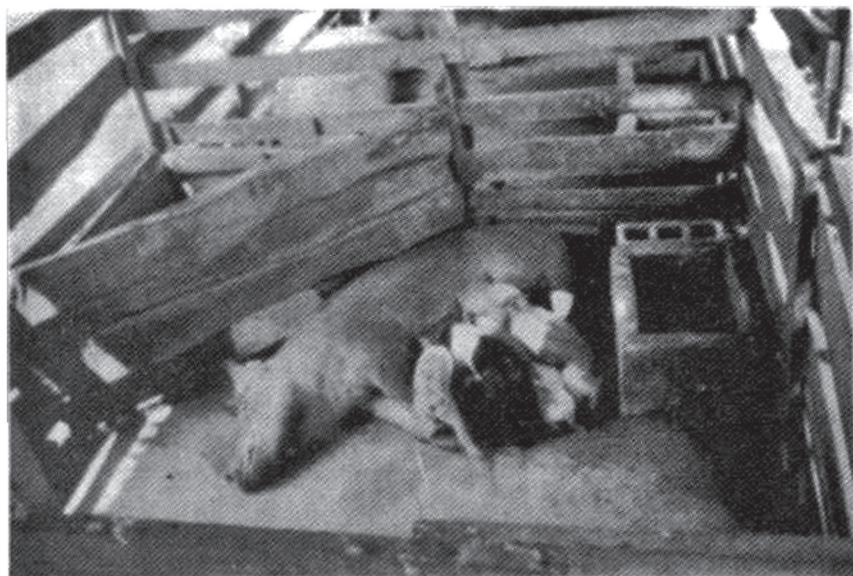

MATERNITY PEN SYSTEM 3

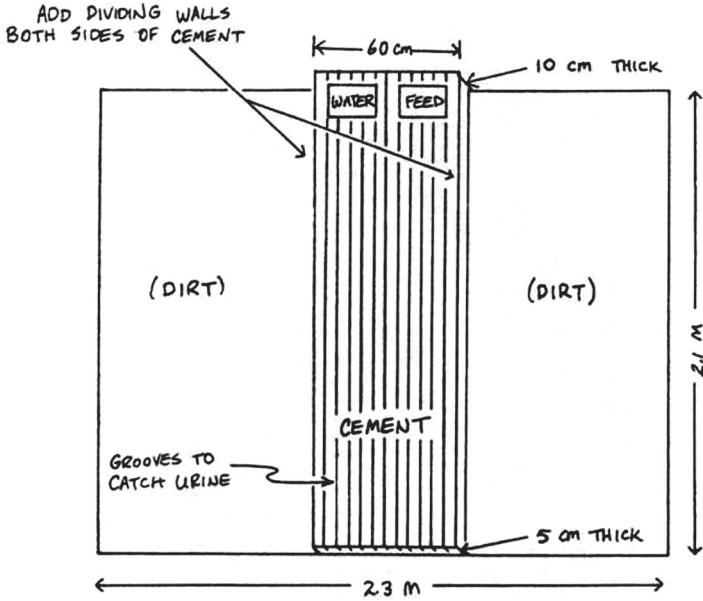

SUPPLIES NEEDED :

- 2 BAGS (40.5 kg) CEMENT
- 10 BUCKETS GRAVEL (19 L BUCKETS)
- 20 BUCKETS SAND (19 L BUCKETS)

Reamy - 2006

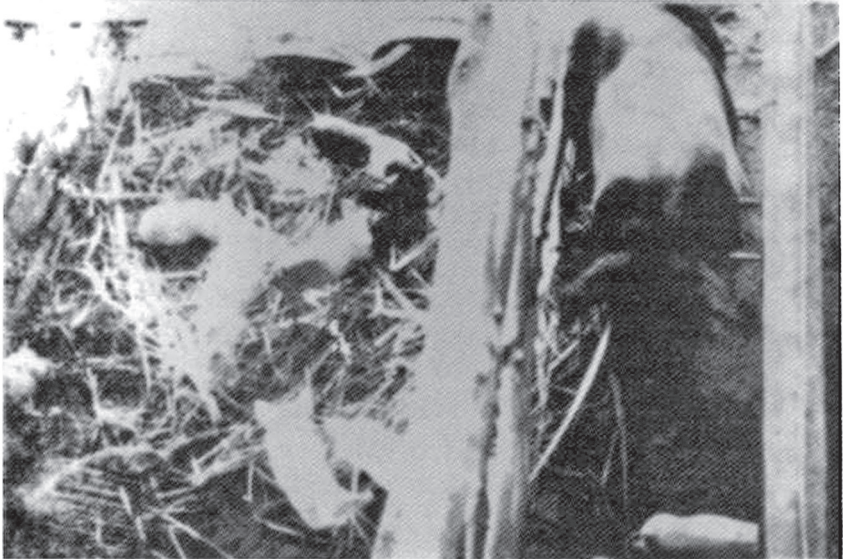

OUTDOOR FEEDERS AND WATERERS

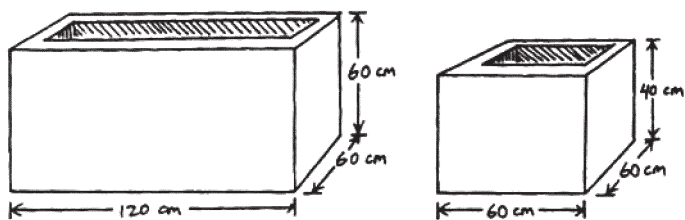

CREEP FEEDER / FIGLET WATERER

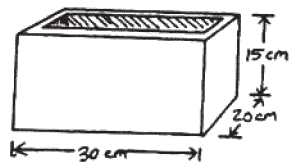

160mm x 526

Section IX

**Consulting By Mail
On Problems in Pigs**

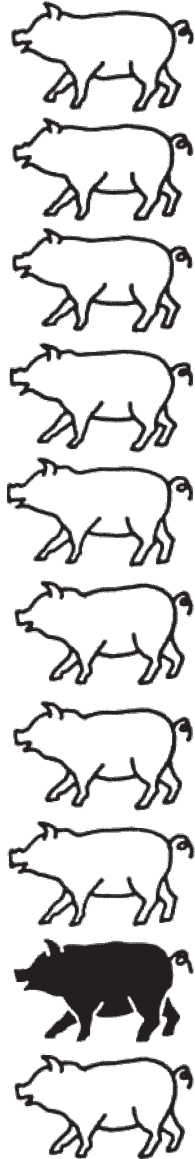

Since this booklet cannot cover all possible aspects of health and production practices in pig raising, Christian Veterinary Missions is providing a method whereby you may obtain additional information, on pig problems in your area.

The following is a general outline of information needed.

1. **Farm Location**

1. Country
2. Area of Country—State or Province
3. Distance and direction from nearest large city

2. **Climate By Season**

Ex. — Winter, December-February. Cool with heavy rains daily. Rest of year—hot and dry.

Give seasonal extreme temperatures and amounts of rain.

3. Description of area where farm is located.

Ex. — High mountain plateau, sparsely populated.

Ex. — Small farms, densely populated area near large city.

Ex. — Rangeland with low swampy areas near streams.

Ex. — Tropical island with coconut and sugar cane plantations.

4. **Description of Farm** in great detail

a. **Terrain**

Ex. — Low, uncleared land with small amounts of well drained cropland being farmed.

Ex. — High mountain valley.

b. Total Acres in Farm - Hectares _____

c. Acres in crops - Hectares _____

d. List crops grown by season _____

e. Acres used for pigs _____

f. Acres used for other livestock _____

g. Number of pigs on farm:

Baby pigs _____

Growing animals _____

Adult Females _____ Sows _____

Adult Males _____ Boars _____

h. List other livestock and poultry on farm.

i. Describe method of confinement, tethered, fenced, running loose, etc.

j. Describe all buildings and sheds; age and condition.

k. Distance to nearest farm with pigs.

l. Do neighboring pigs run loose?

5. **Management Practices**

- a. Sanitation — good, bad or fair, describe.
 - b. Nutrition — in great detail.
 - what foods are fed and to each age group.
 - how much of each is fed.
 - season variation.
 - include minerals and salt.
 - c. Drinking Water
 - Source -well, stream, pond
 - how supplied - trough, etc.
 - d. How are animals protected from extremely hot and cold weather.
 - e. List worm and insect control practices and drugs; what, when, how much, how used.
 - f. Vaccines used; what, when, how.
 - g. Weaning age.
 - h. Are survivors stunted, mild or severe.
 - i. Is reproduction affected? _____. Describe
 - j. Is appetite affected? _____. Describe.
 - k. Body temperature while sick.
 - l. Describe all symptoms in great detail.
 - m. Describe all treatments used and results.
7. Any Other Observations. Remember, no detail is too trivial to be of importance.

However, feel free to correspond with us in any manner that you choose, and on any matter that you would like to obtain information relating to pig production.

E-Mail to:

Christian Veterinary Mission
cvminfo@cvmusa.org

or mail to the author, Dr. D.E. Goodman
c/o Christian Veterinary Mission
19303 Fremont Avenue North
Seattle, WA 98133 USA

Section X

Acknowledgements



ACKNOWLEDGEMENTS

The author has received information from many individuals and sources in preparing this booklet. He is very grateful for their assistance. If anyone or any source has been omitted, it is an oversight and apologies are in order.

Special Acknowledgement

Dr. Bruce Lawhon, Extension veterinarian at the college of Veterinary Medicine at Texas A and M Univ. for major contributions to this Revised Edition.

1. Mr. Carl Ackerman, Clemson University, Clemson, South Carolina, for many helpful tips and for proofreading
2. Dr. Joseph H. Conrad, University of Florida for information on Tropical Nutrition.
3. Dr. Roger Henken, University of Kentucky for highly detailed nutritional information.
4. Mr. C.H. McGowan, Tuskegee Institute, Alabama for much helpful information.
5. Dr. John R. Leahy, Oneonta, NY for permission to use material from the book Restraint of Animals.
6. Dr. Rod Frank, Minneapolis, Minnesota for material used in the section on confinement.
7. Dr. Maureen Birmingham, -formerly in Haiti, now with World Health Organization, Geneva, Switzerland for material used in the section on confinement.
8. Dr. Gordon L. Coppoc and Mr. R. Kinsell, Purdue University, for material used in the section on Basic Treatment.
9. Mr. James McGrann, presently in Panama, for information.
10. Dr. Roger De Haan, Mission De Cristo, Columbia.
11. Dr. John G. Murray, Clemson University, SC, USA
12. Jim Collier, Manchester, GA, for overall help with the project and proofreading final copy.
13. Dr. David Reeves, Univ. of Georgia, School of Veterinary medicine
14. Dr. Ray Hines, Clemson Univ. Animal Diagnostic Laboratory
15. Dr. John Albrecht, College of Agr, Clemson Univ

Sources of Information:

1. Agricultural Extension Service of State Universities as follows:

- A. Auburn University, Alabama
- B. University of California
- C. Clemson University, South Carolina, USA
- D. University of Florida
- E. University of Hawaii
- F. University of Illinois
- G. Iowa State University
- H. University of Kentucky
- I. Mississippi State University
- J. Montana State College
- K. North Carolina State University

- L. University of Nebraska
- M. North Dakota State University
- N. Pennsylvania State University
- O. Purdue University, Indiana
- P. Colorado State University
- Q. Tuskegee Institute, Alabama
- R. University of Tennessee
- S. Utah State College
- T. Virginia Polytechnic Institute
- U. University of Georgia
- V. Oklahoma State University

2. **United States Department of Agriculture**

3. **Farm and Livestock Magazines**

- A. *Hog and Farm Management*
- B. *National Hog Farmer*
- C. *Pig America*

4. **International Rice Research Institute** of the International Institute of Rural Reconstruction in the Phillipines.

5. Mrs. Billie Jones, Columbia, SC for highly proficient typing of the original editions.

6. ***Special thanks to United Methodist Women of Pine Grove United Methodist Church, Turbeville, South Carolina, for their generous financial assistance in preparing the first edition***

7. Mrs. Julie Griffin, Turbeville, SC, USA for metric translations.

8. ***Our thanks to the following for their assistance in developing time line drawings with Metric dimensions:***

- A. **Dr. Todd Cooney, Indiana, USA**
- B. **Shannon Smith, Virginia, USA**
- C. **Marion Bowser, Florida, USA**
- D. **Dr. Bill Robertson, California, USA**
- E. **Laurie Lang, North Carolina, USA**

Disclosure: CVM or its authors do not endorse any brand name., mentioned in book.

WEIGHT AND MEASURE

.3937 inch =	1 centimeter
1 inch =	2.54 centimeters
12 inches = 1 foot =	.3048 meter
3 feet = 1 yard =	.9144 meter
39.37 inches =	1 meter
5,280 feet = 1 mile =	1.609 kilometers
1 acre = 43,560 square feet	.405 hectares
4,840 square yards	.405 hectares
2.471 acres =	1 hectare

To change centigrade to Fahrenheit multiply by $\frac{9}{5}$ and add 32

To change Fahrenheit to centigrade subtract 32 and multiply by $\frac{5}{9}$

1 milligram = .015 grain
1 ounce = 437.5 grains = 28.350 grams
1 pound = 453.592 grams
1,000 grams = 1 kilogram = 2.205 pounds
2,000 pounds = 1 net or short ton
2,204 pounds = 1 metric ton

16 ounces = 1 pint = .473 liter
2 pints = 1 quart (US) = .946 liters

1000 milliliters (ml) = 1 liter
1 milliliter = 1 cubic centimeter (cc)
1 teaspoon = 5 milliliters = $\frac{1}{3}$ tablespoon
1 tablespoon = 15 milliliters = $\frac{1}{2}$ ounce
8 ounces = 1 cup

Christian Veterinary Mission (Publisher of this book)

Our vision is to see

Christ's love expressed through veterinary medicine.

Our mission is to

challenge, empower and facilitate veterinarians to serve through their profession, living out their Christian faith.

CVM also provides education and encouragement for those who desire to minister through service, prayer, relationship building, and modeling Christ's love.

About CVM

Christian Veterinary Mission (CVM) is a registered non-profit Christian Service Organization 501(c)(3) based in Seattle, Washington, U.S.A.

CVM was founded in 1976 by Dr. Leroy Dorminy who came to realize the impact that veterinarians could have by integrating their faith with their practice, both locally and around the world. In 2008, CVM had nearly 30 veterinary professionals serving full-time internationally and over 200 veterinary professionals and student volunteers serve on short-term cross-cultural mission trips annually. CVM sponsors fellowship & prayer breakfasts at over 20 U.S. veterinary meetings each year and reaches out to veterinary students through Christian Veterinary Fellowship (CVF) groups in every veterinary school in the U.S. by encouraging them in spiritual growth and professional development.

There are over 3,500 veterinarians affiliated with CVM in the U.S. CVM also partners with organizations and networks in other countries that are focused on empowering Christian veterinarians. CVM has a volunteer advisory board of veterinarians who guide its vision, mission, and programming.

CVM books and the free International Animal Health Newsletter were written with small farmers, veterinarians, and agricultural development workers in mind. Our desire is that they would help individuals and groups develop an appropriate livestock program to meet community needs. CVM's Endowment Fund was started in the early years of the organization's life. The fund provides for meaningful programs that could not be funded by the regular budgeting process.

NOTES